

# **EXECUTE** **XQ1S**

1/10 COMPETITION TOURING CAR

**INSTRUCTION MANUAL**

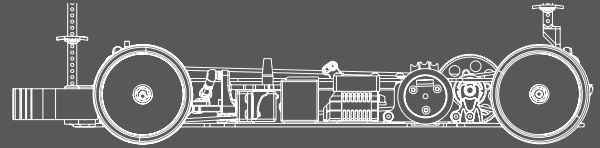

### Bag A,F , HW A,B



Turnbuckle M3 x 39mm  
XP-10157



Turnbuckle M3 x 29mm  
XP-10156



Turnbuckle M3 x 18mm  
XP-10157

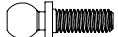

4.8mm Ball End 8mm Thread  
XP-10150



4.8mm Ball End 6mm Thread  
XP-10149



4.8mm Ball End 5mm Thread  
XP-10148

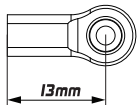
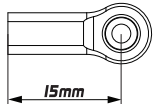

4.7mm Ball End Set  
XP-10002

Use the multi-tool to measure length links

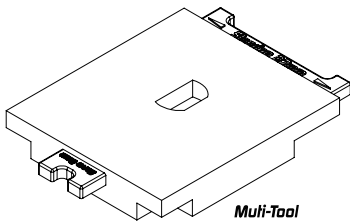

Multi-Tool

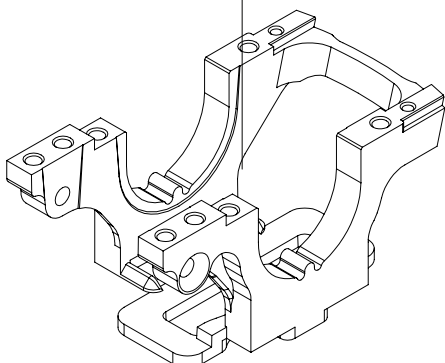

**2X**

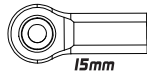

15mm

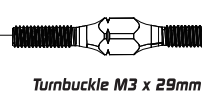

Turnbuckle M3 x 29mm

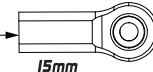

15mm

For Rear Camber Link

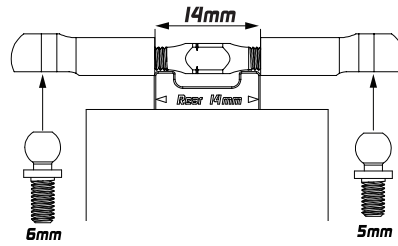

**2X**

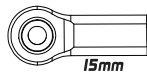

15mm

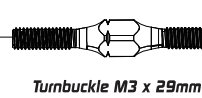

Turnbuckle M3 x 29mm

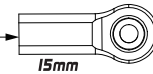

15mm

For Front Camber Link

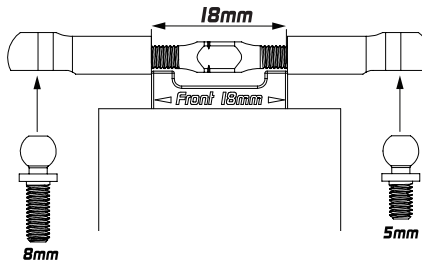

**2X**

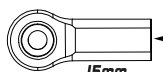

15mm

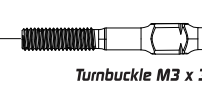

Turnbuckle M3 x 39mm

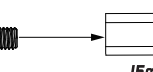

15mm

For Steering

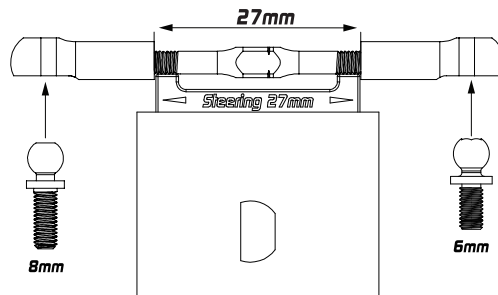

**1X**

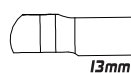

13mm

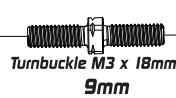

Turnbuckle M3 x 18mm

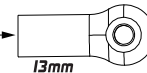

13mm

For Servo

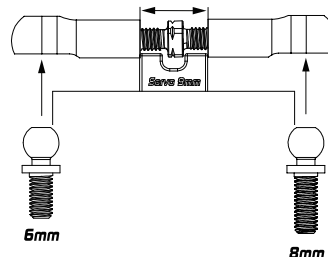

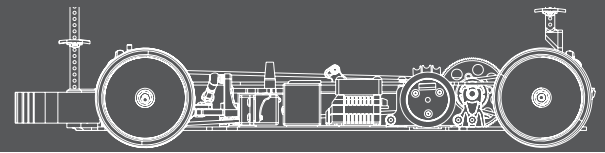

## Bag B , Bag C , HW H , HW J

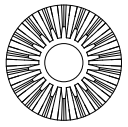

Bevel Gears 18T  
XP-10009



Bevel Gears 10T  
XP-10009

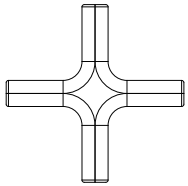

Gear Diff Cross Pin  
XP-10009

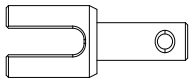

Steel Gear Diff Outdrive Adapter  
XP-10288

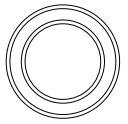

Bearing 10 x 15 x 4mm  
XP-40065



O-ring 5 x 2mm  
XP-10184



Pin 2 x 9.8mm  
XP-40069

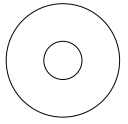

Spacer 5 x 15 x 0.4mm  
XP-10181



Spacer 3.6 x 9.5 x 0.2mm  
XP-10182



Flat Head Screw M2.5 x 10mm  
XP-40044

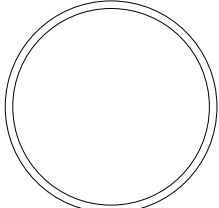

O-ring 25 x 1mm  
XP-10183

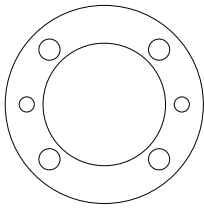

Diff Gasket  
XP-10179

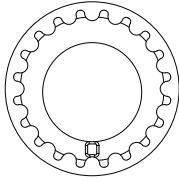

Composite Adjustment  
Ball-Bearing Hub  
XP-10107

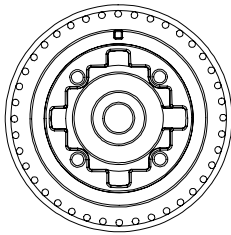

Gear Differential Case  
XP-10008

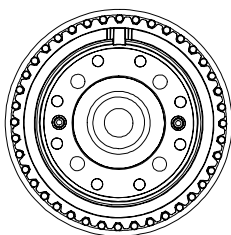

Gear Differential Cover  
XP-10008

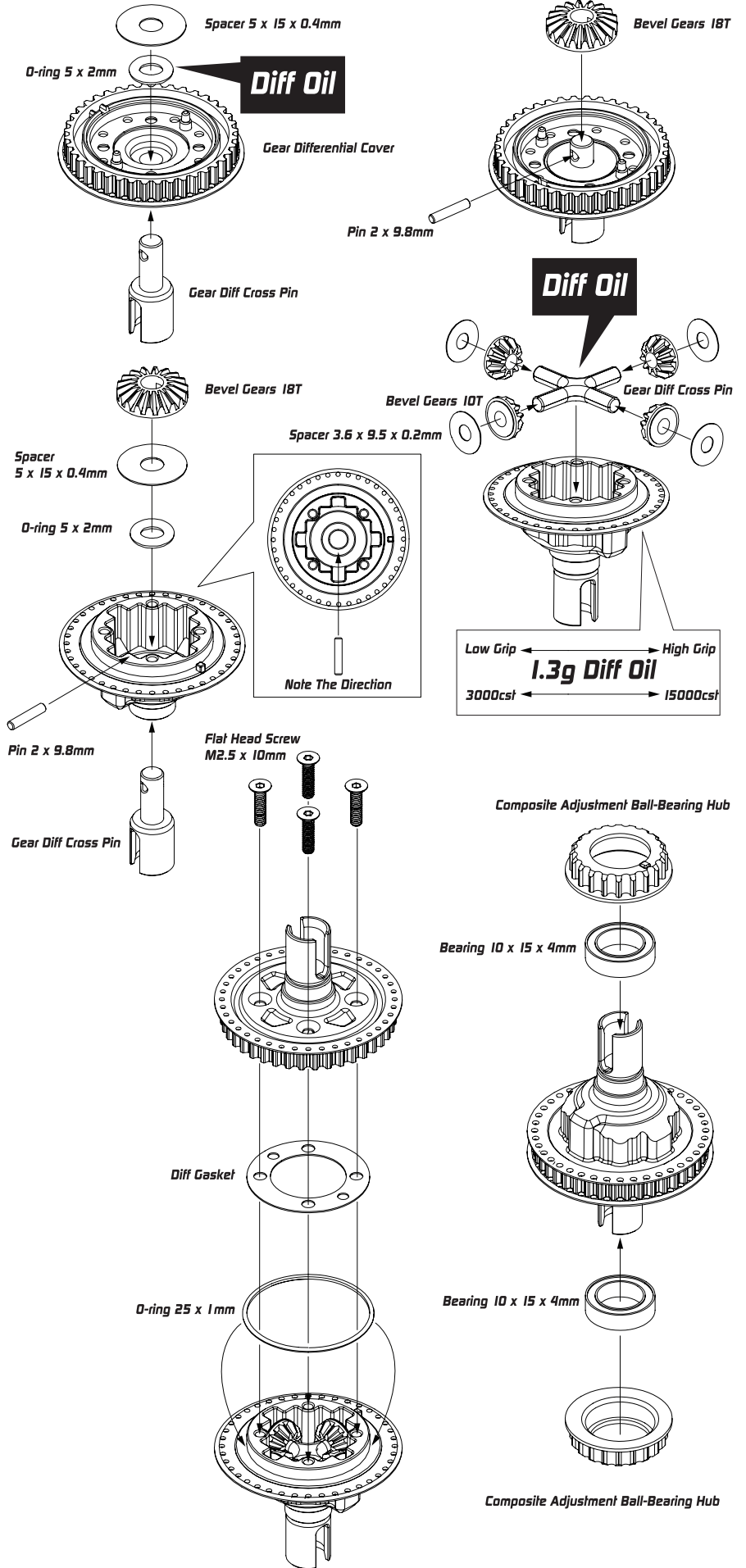

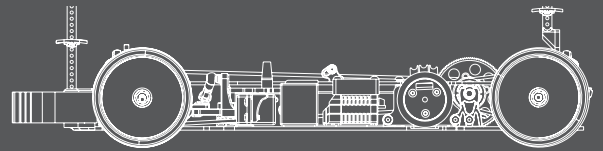

### Bag C, HW H

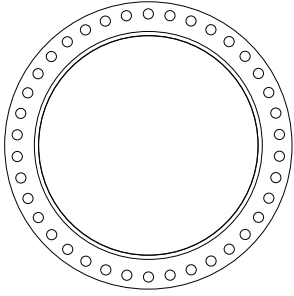
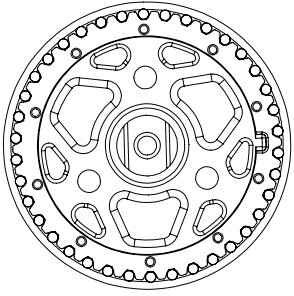

Composite 3BT Spool Set  
XP-10264

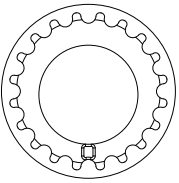

Composite Adjustment Ball-Bearing Hub  
XP-10107

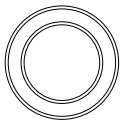

Bearing 10 x 15 x 4mm  
XP-40065

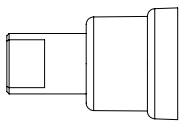

Composite Axle Driveshaft Adapters Set  
XP-10264



Button Head Screw M3 x 12mm  
XP-40040

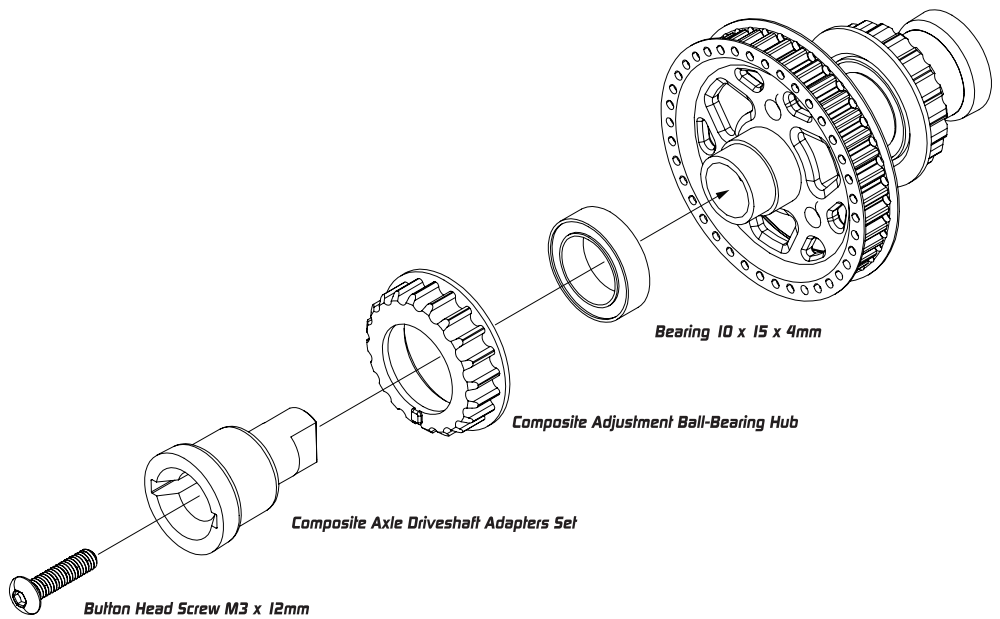
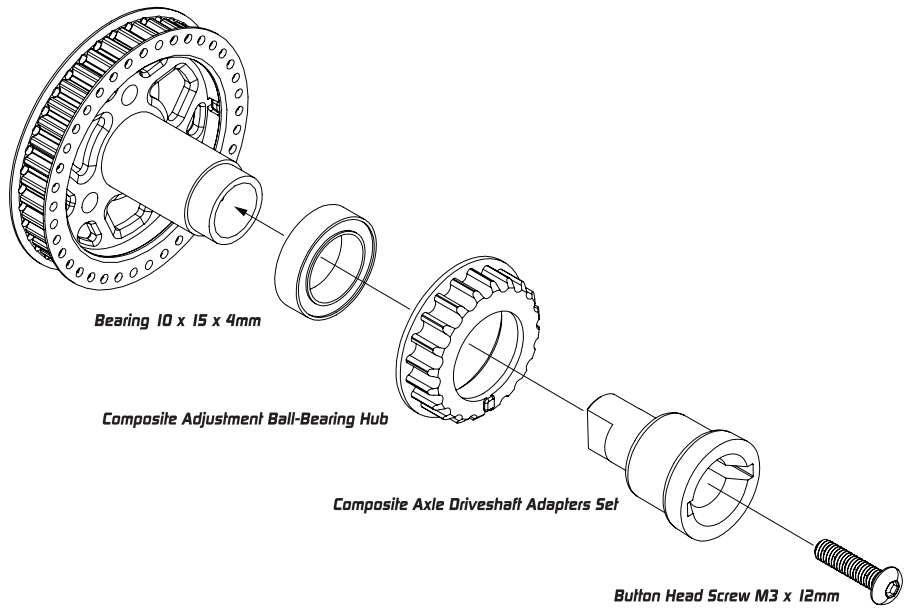
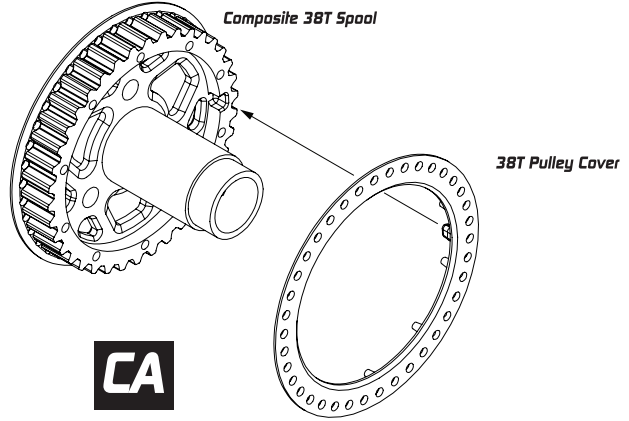

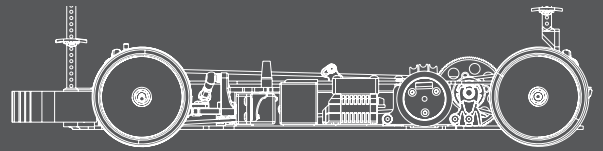

### Bag D

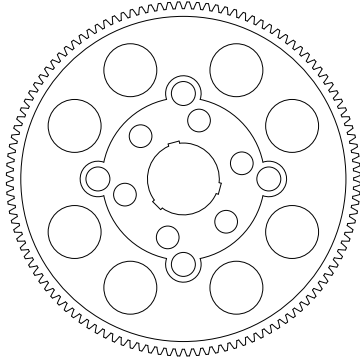

Spur Gear 64P 116T  
XP-10053

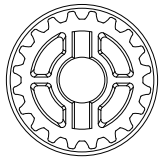

20T Center Pulley  
XP-10134

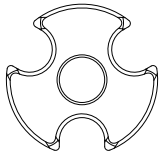

Center Pulley Cover  
XP-10134

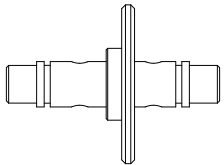

XQ1-S Aluminium Solid Layshaft  
XP-10284



Button Head Screw M3 x 4mm  
XP-40036

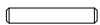

Pin 2 x 12mm  
XP-40070



M5 E-Clip  
XP-40058

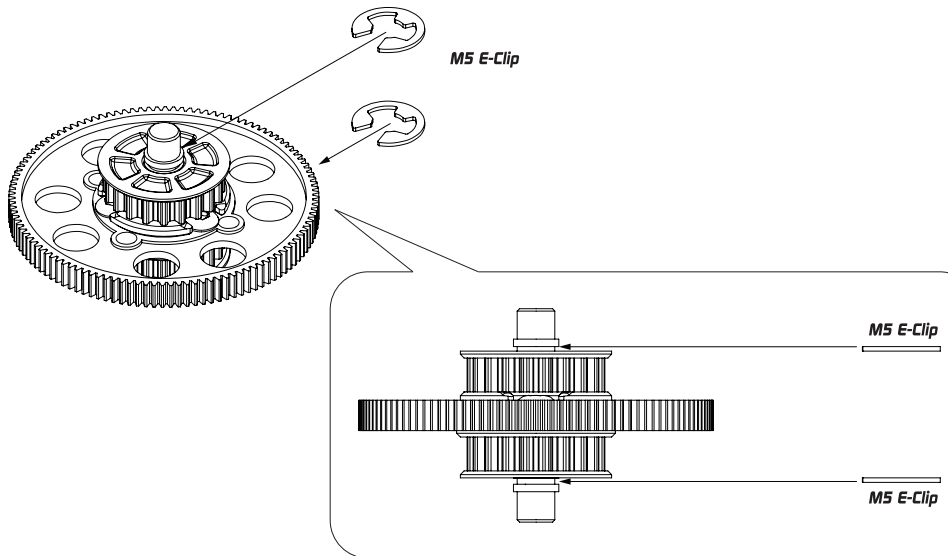
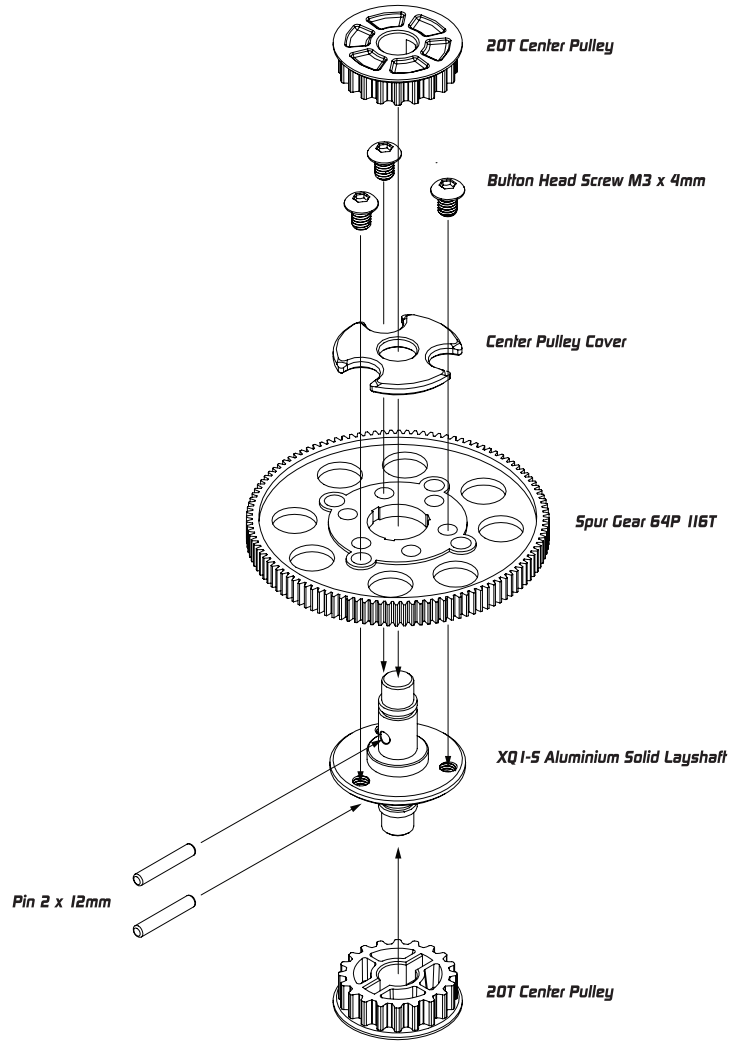

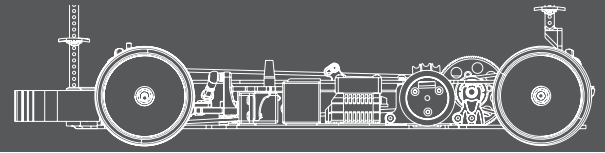

### Bag F, G, K, L, HW H, K

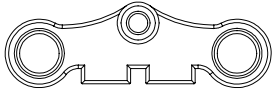

Composite Steering Plate For Dual Servo Saver XP-10261

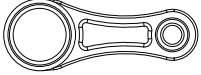

Composite Dual Servo Saver Arm XP-10261



Bearing 5 x 8 x 2.5mm XP-40061



Bearing 3 x 6 x 2.5mm XP-40060



3 x 6 x 1mm Composite Spacer XP-10261



Round Head Screw M3 x 8mm XP-40038



Bulfin Head Screw M3 x 6mm XP-40037

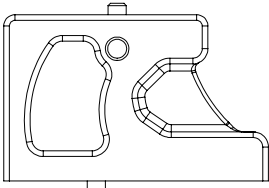

Composite Servo Mount XP-10261

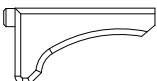

Composite Servo Side Mount XP-10261



Servo Horn 23T for Sanwa, KD XP-10163



Servo Horn 25T for Fulaba XP-10163

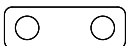

Servo Spacer XP-10136

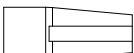

Antenna Holder XP-10001



Flat Head Screw M3 x 10mm XP-40049



Flat Head Screw M3 x 6mm XP-40046



Battery Stopper XP-10185

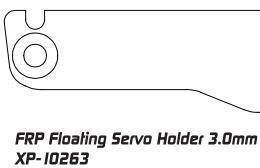

FRP Floating Servo Holder 3.0mm XP-10263

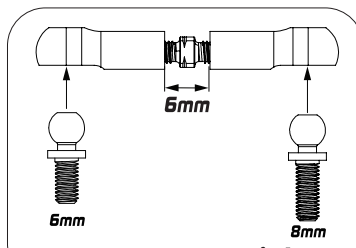

From Servo Link

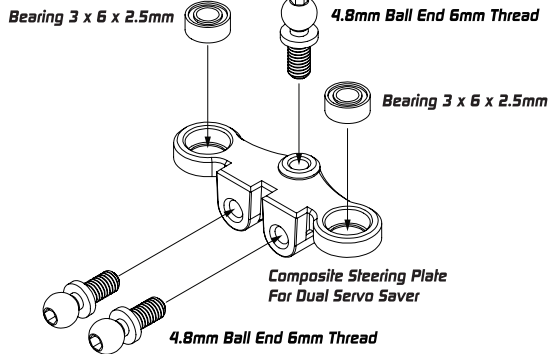

Composite Steering Plate For Dual Servo Saver

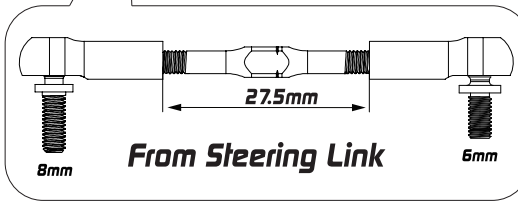

From Steering Link

Bulfin Head Screw M3 x 6mm



Bearing 5 x 8 x 2.5mm

Bulfin Head Screw M3 x 6mm

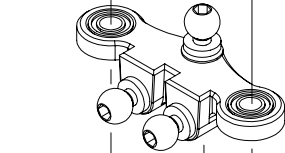

Composite Dual Servo Saver Arm

Composite Dual Servo Saver Arm

Bearing 5 x 8 x 2.5mm

Flat Head Screw M3 x 6mm



Antenna Holder

Flat Head Screw M3 x 10mm



Flat Head Screw M3 x 6mm



FRP Floating Servo Holder 3.0mm

Battery Stopper

Flat Head Screw M3 x 6mm



Composite Servo Mount

Flat Head Screw M3 x 6mm

Servo Spacer

No Electronics are included

Servo Spacer

Round Head Screw M3 x 8mm



3 x 6 x 1mm Composite Spacer



4.8mm Ball End 8mm Thread

Round Head Screw M3 x 8mm



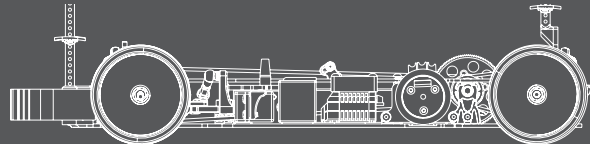

Bag E, G, HW C, E, H, K

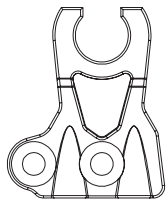

Composite Layshaft Bulkhead  
XP-10116

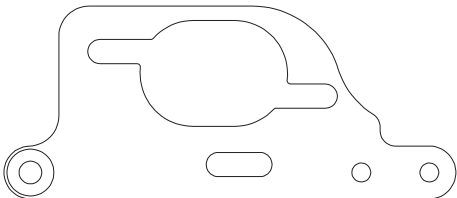

Alu Motor Mount Plate  
XP-10232

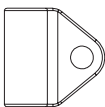

Alu Motor Mount Center Support  
XP-10232



3 x 6 x 1 mm Composite Spacer  
XP-10261

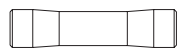

XQ15 Aluminum Center Post  
XP-10259



Bulth Head Screw M3 x 6mm  
XP-40037



Flat Head Screw M3 x 12mm  
XP-40050



Flat Head Screw M3 x 10mm  
XP-40049



Flat Head Screw M3 x 6mm  
XP-40046



Bearing 5 x 10 x 4mm  
XP-40064

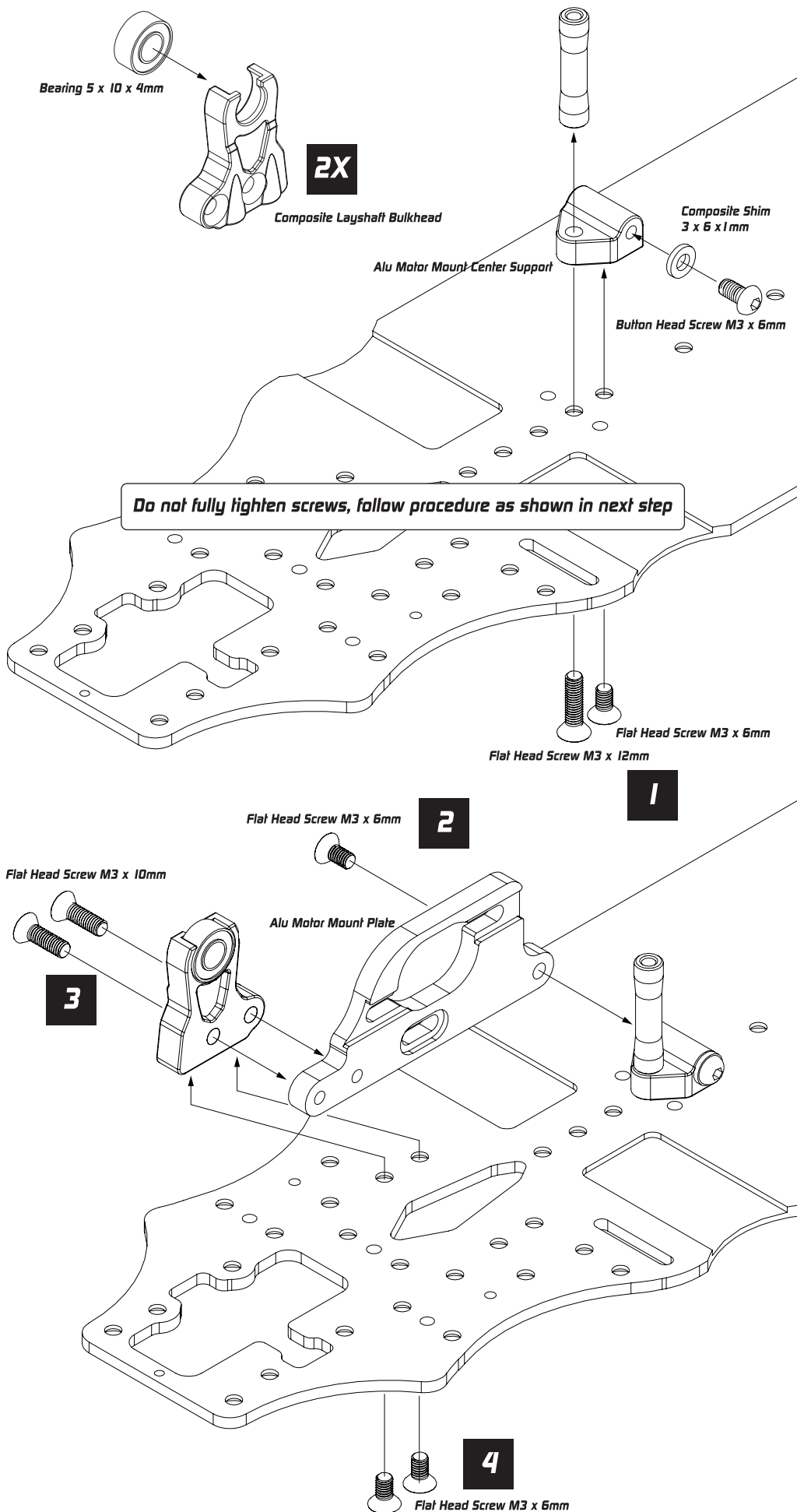

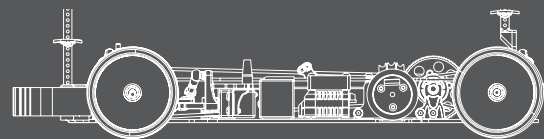

### Bag I , F , HW K

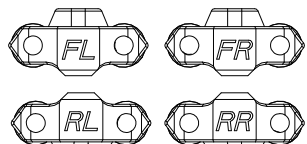

Composite Lower 2-Piece Suspension Holder FL,FR,RL,RR  
XP-10260

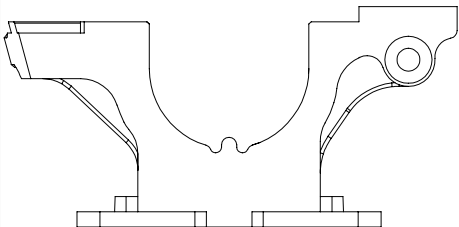

Composite Lower Bulkhead  
XP-10229



Flat Head Screw M3 x 8mm  
XP-40048



Flat Head Screw M3 x 6mm  
XP-40046

Optional

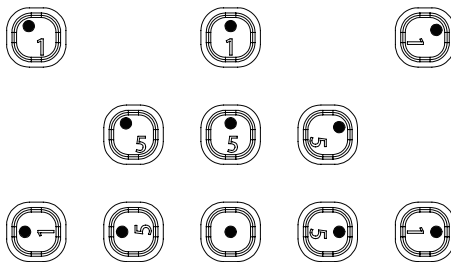

**Diagonal Offset**  
Use either 0.5 or 1 mm to shift the roll center in a diagonal direction from the center.

**4X**

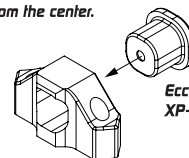

Eccentric Bushing Set  
XP-10127

Alu Lower 2-Piece Suspension Holder XP-10123

**Horizontal Offset**  
Choice of either 0.5 or 1 mm offset from center

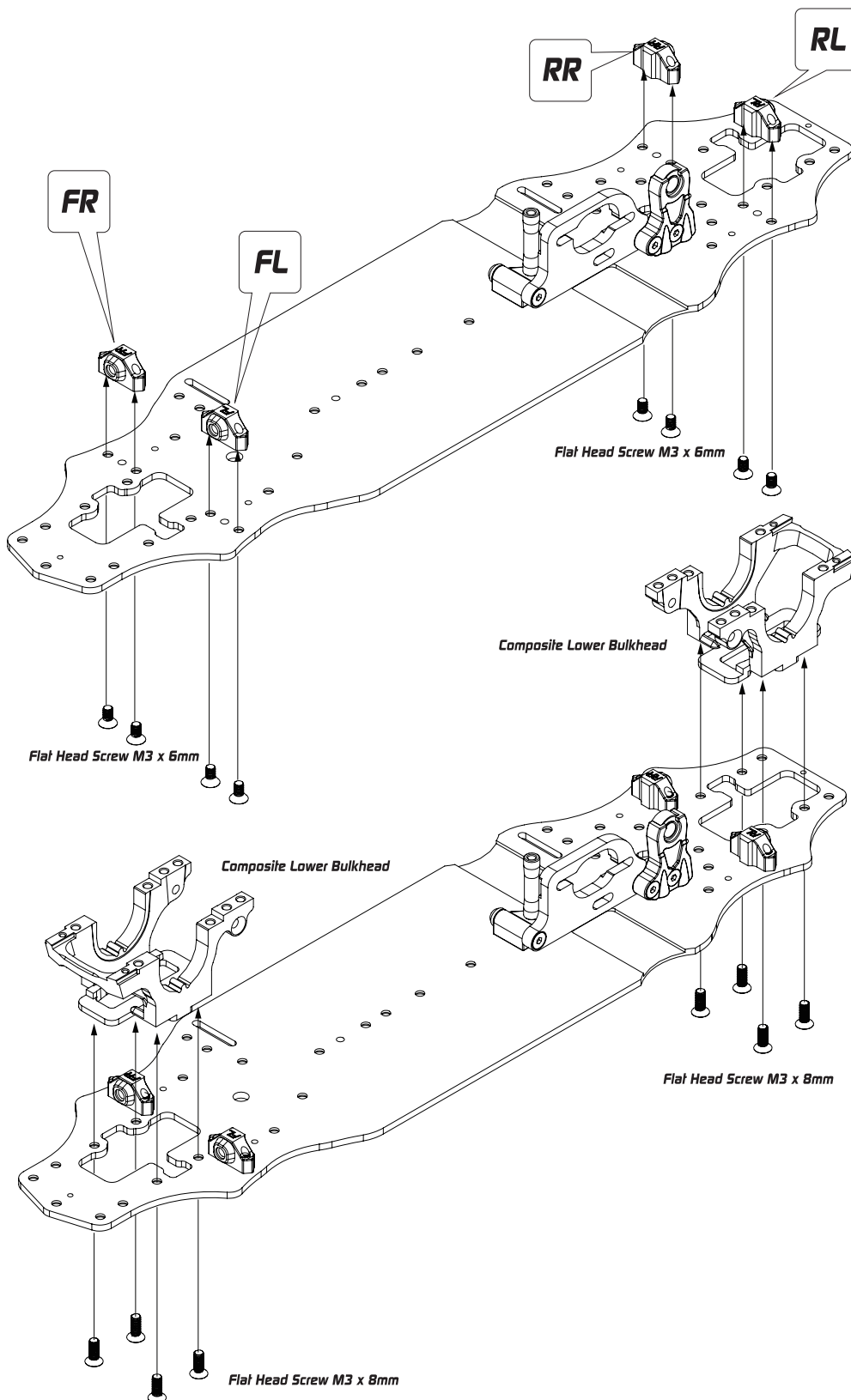





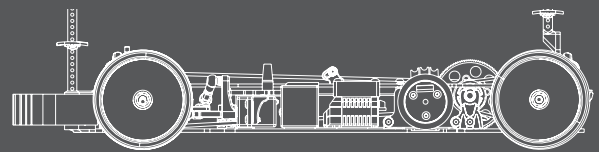

Bag H , HW K

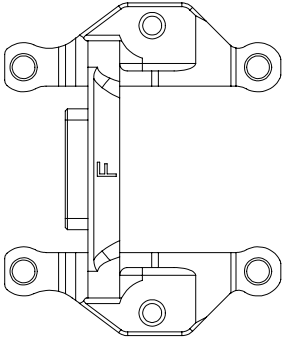

Composite One Piece Upper Clamp Front  
XP-10230

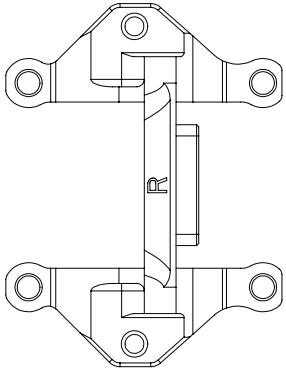

Composite One Piece Upper Clamp Rear  
XP-10230



Round Head Screw M3 x 8mm  
XP-40038

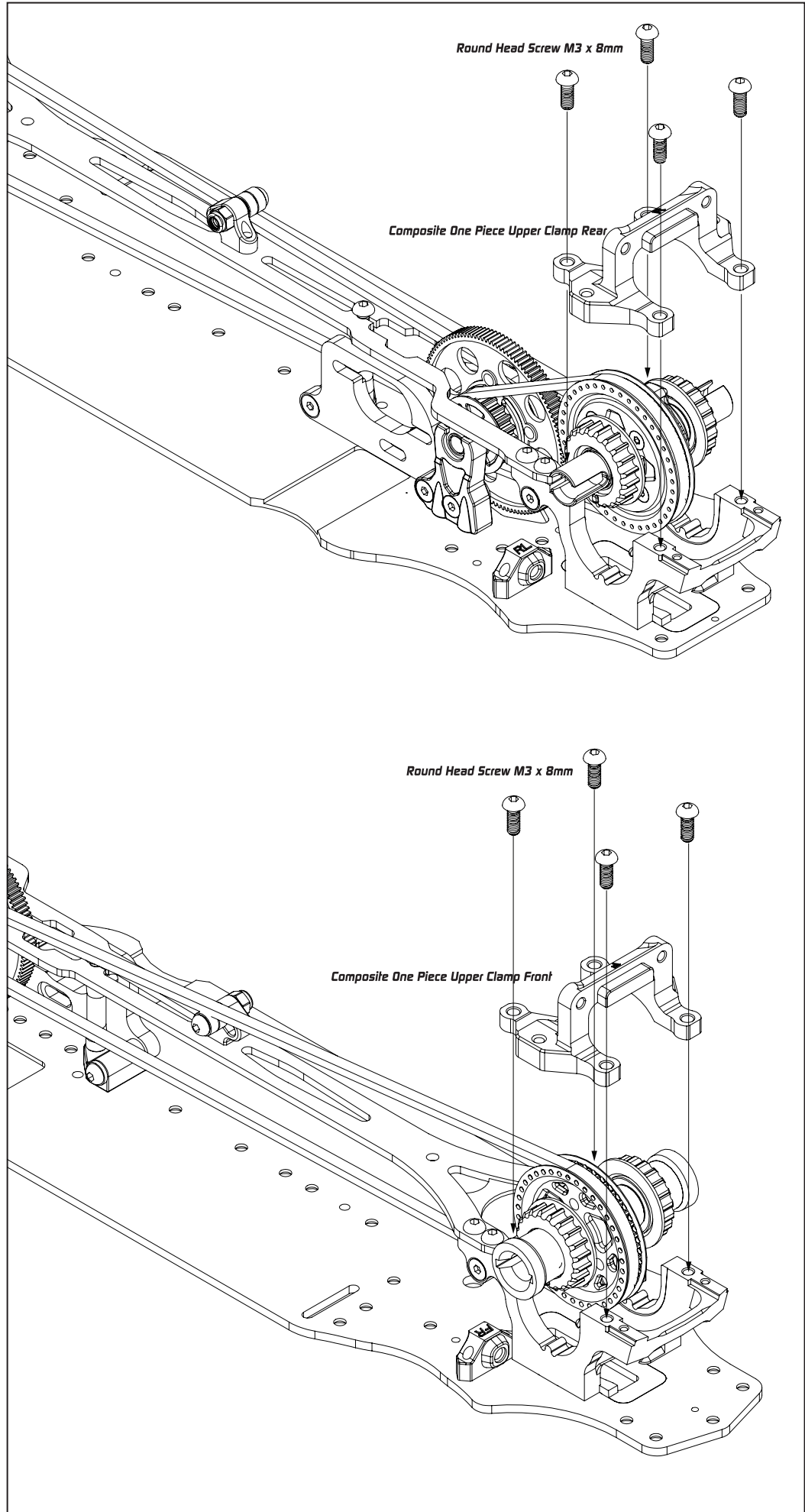

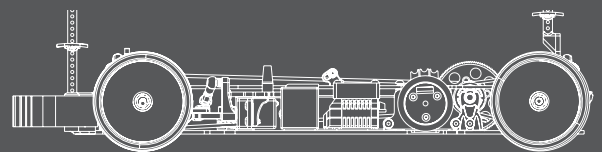

### Bag F, HW K

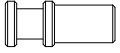

Composite Steering Post For Dual Servo Saver  
XP-10261



Flat Head Screw M3 x 6mm  
XP-40046



Button Head Screw M3 x 6mm  
XP-40037

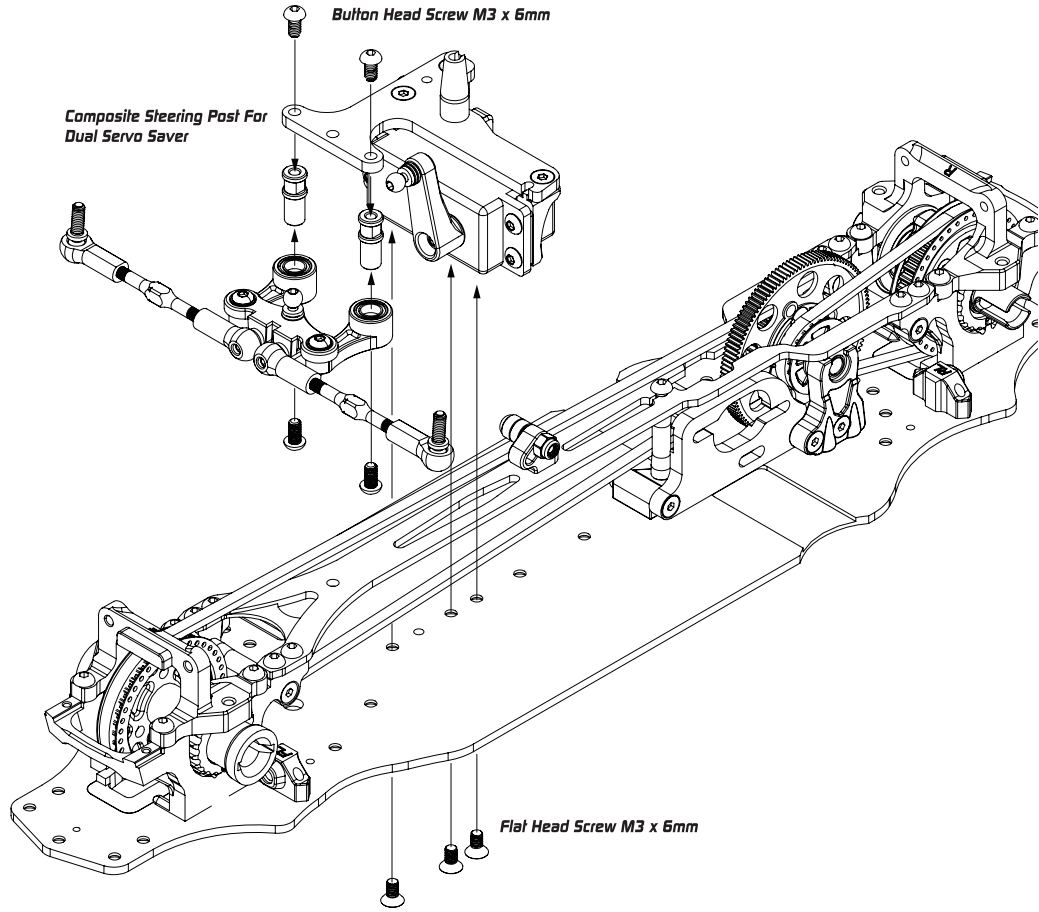

### Non-Floating Steering (Optional)

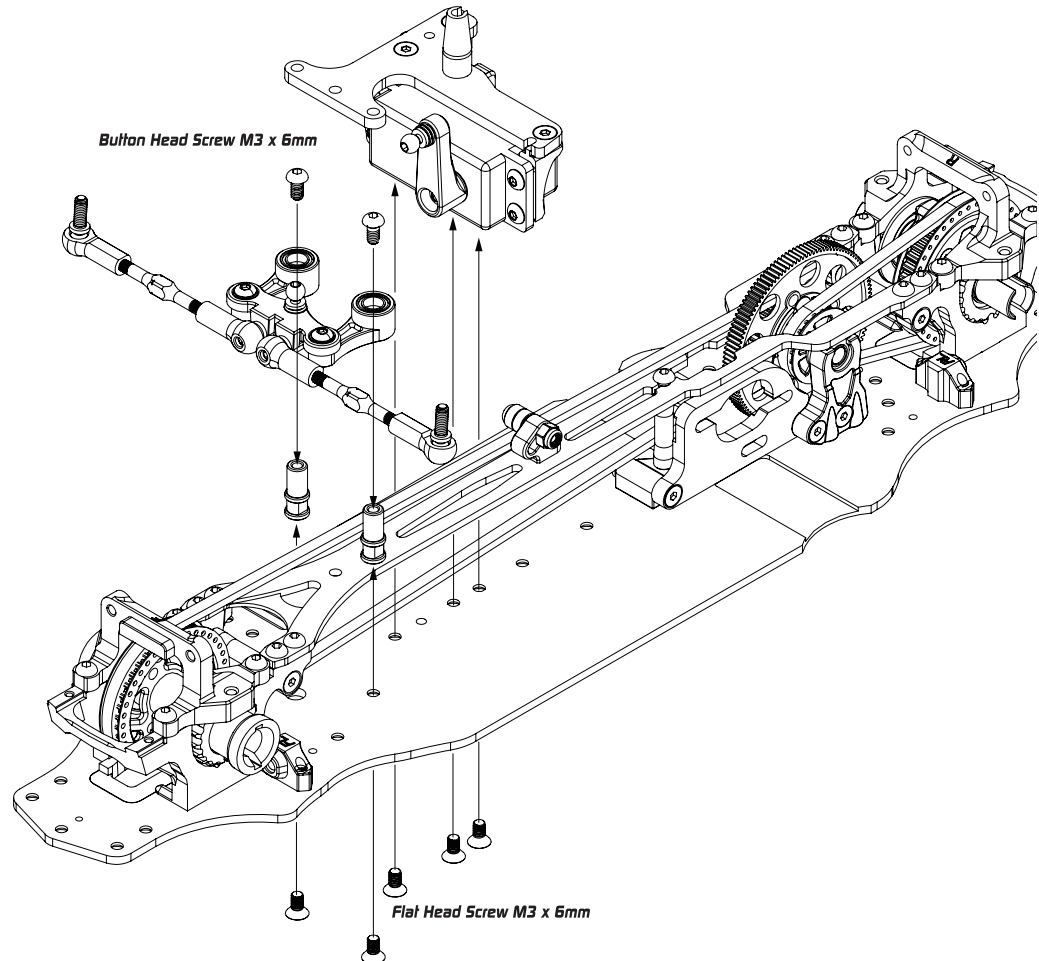

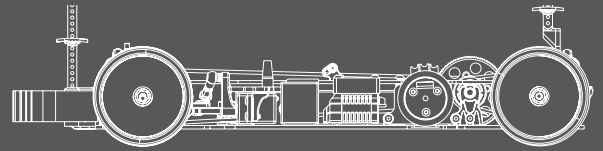

**Bag E, J, HW F, H, I, K**

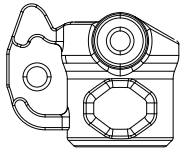

Composite Steering Block Right  
XP-10109

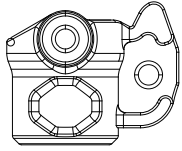

Composite Steering Block Left  
XP-10109

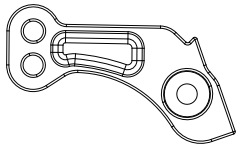

Composite Steering Block  
Plate Right  
XP-10109

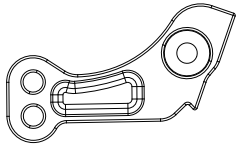

Composite Steering Block  
Plate Left  
XP-10109

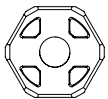

Composite Wheel Hub  
XP-10262



Bearing 5 x 10 x 4mm  
XP-40064



Pin 2 x 9.8mm  
XP-40069



Round Head Screw M3 x 8mm  
XP-40038

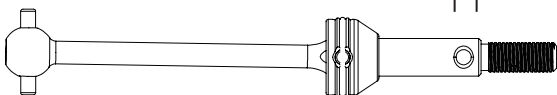

XQ1-5 Steel Universal Shaft  
XP-10244

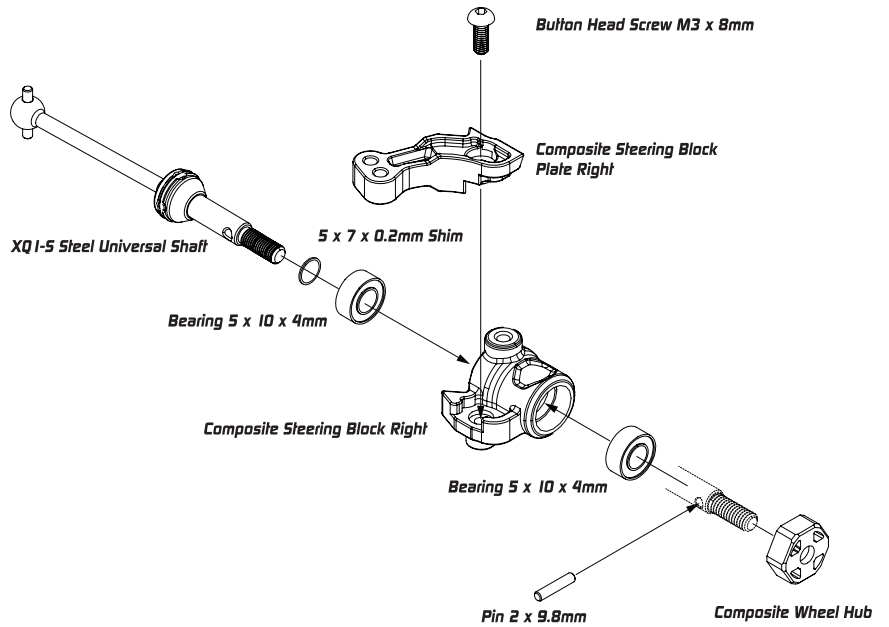
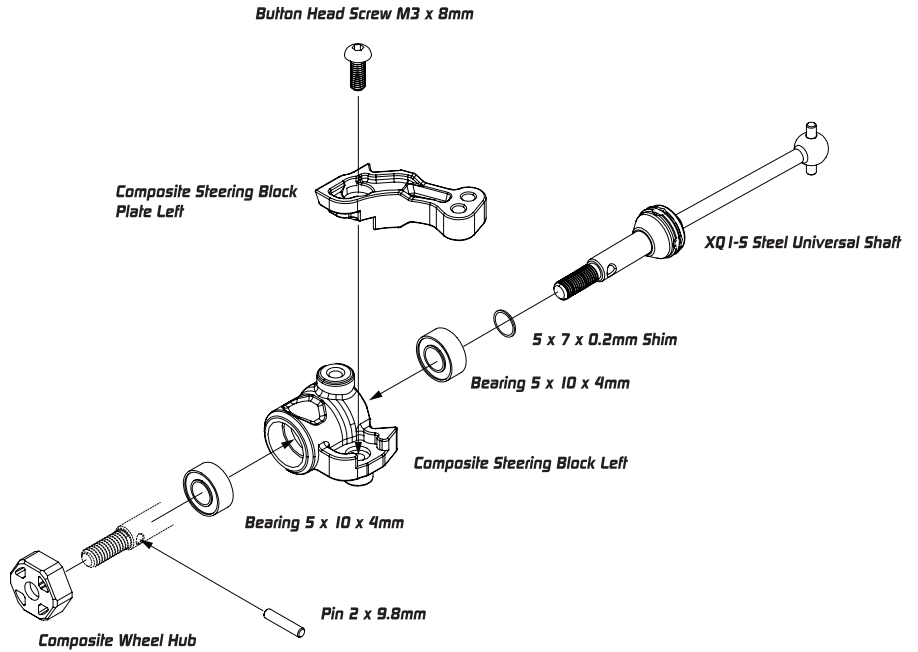

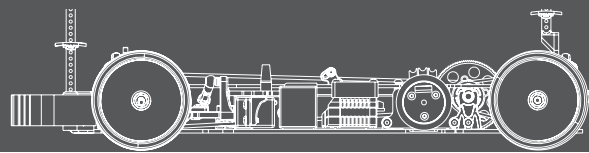

Bag J, L, HW I, K

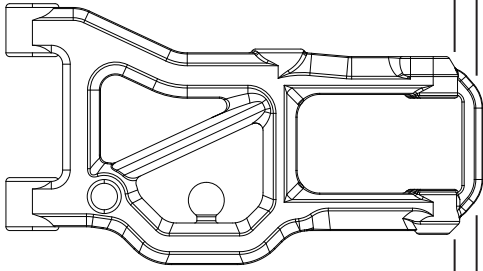

Composite Suspension Arm Front  
XP-10108

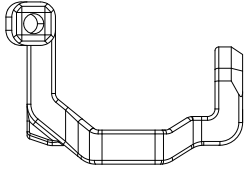

Composite C-Hub - 4° deg Left  
XP-10110

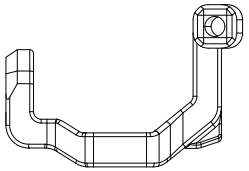

Composite C-Hub - 4° deg Right  
XP-10110

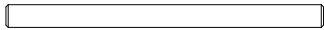

Suspension Pivot Pin 3 x 42mm  
XP-10139

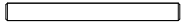

Arm Pivot Pin 2.3 x 23mm  
XP-10140



Arm Pivot Pin Screw M2 x 3.5mm  
XP-10165



Hex Set Screw M4 x 10mm  
XP-40056



Hex Set Screw M3 x 8mm  
XP-40054

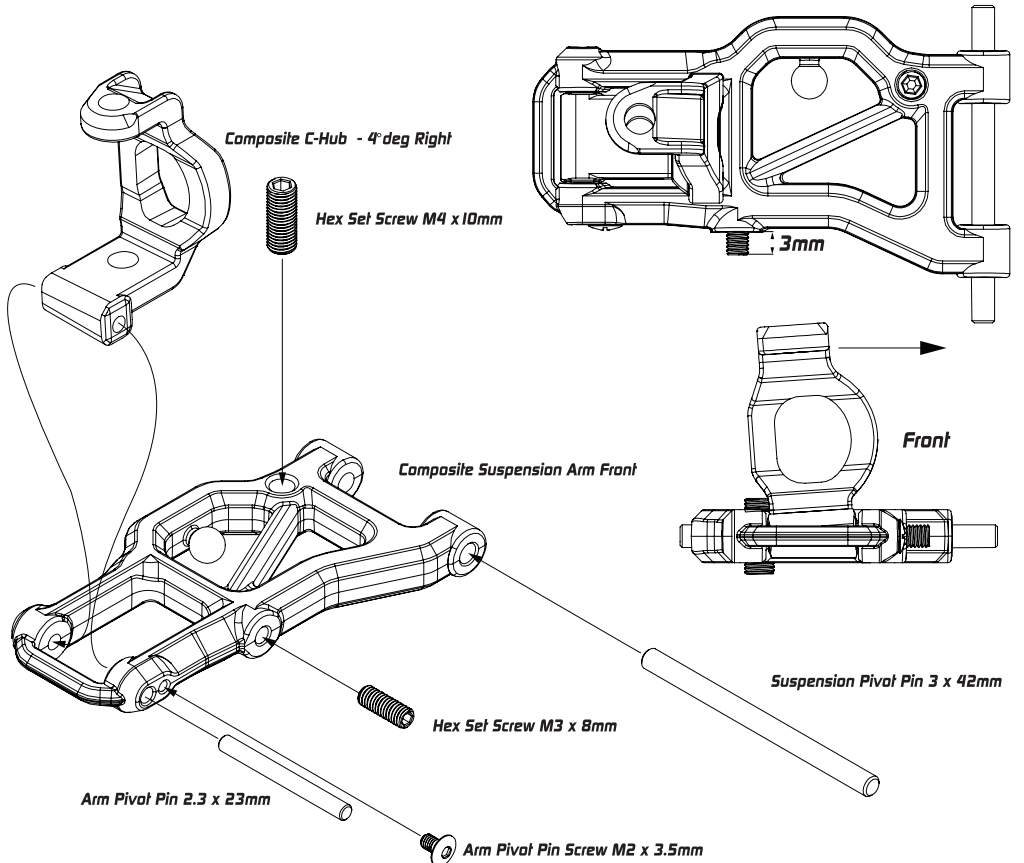
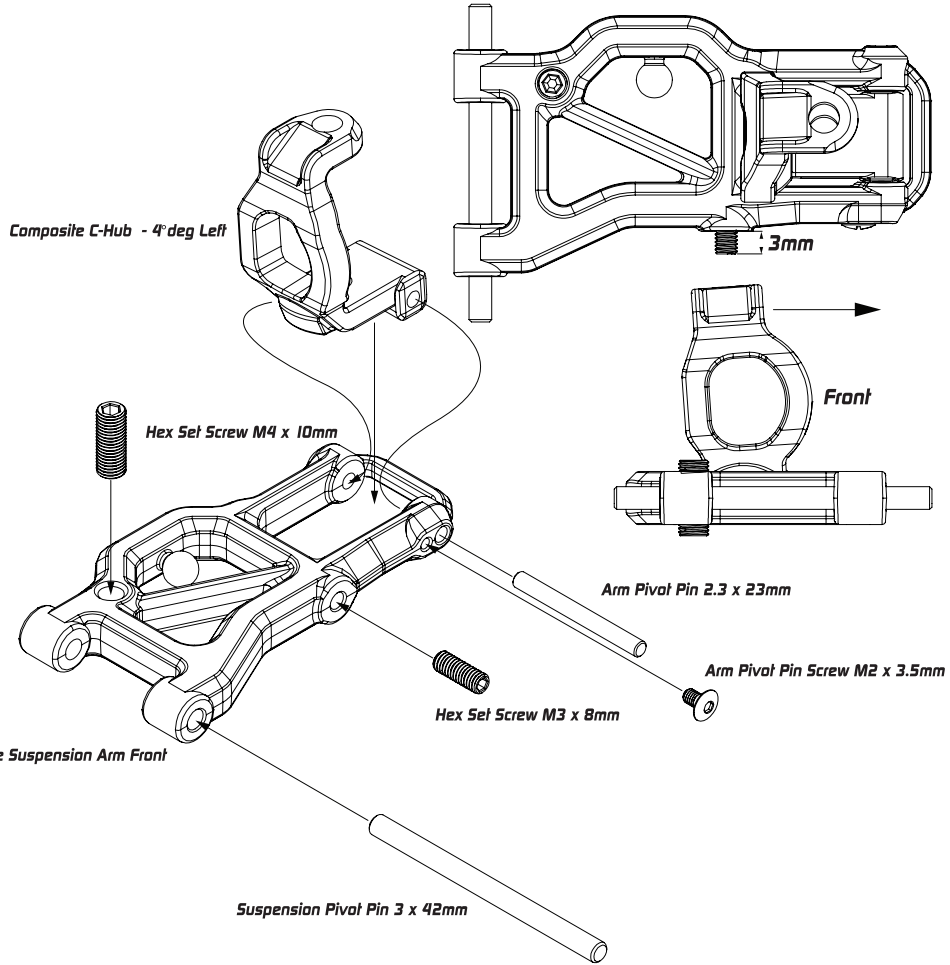

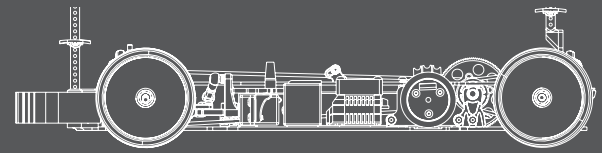

### HW G

  King Pin Collar  
XP-10164

 King Pin  
XP-10164

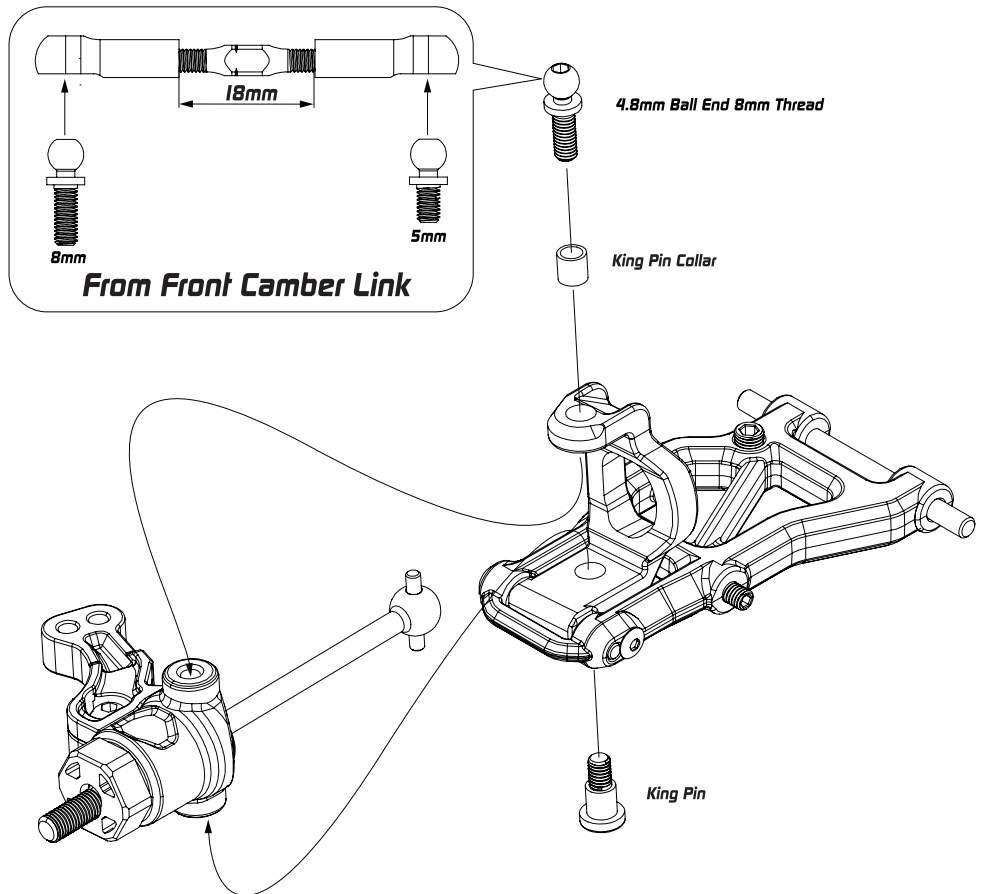
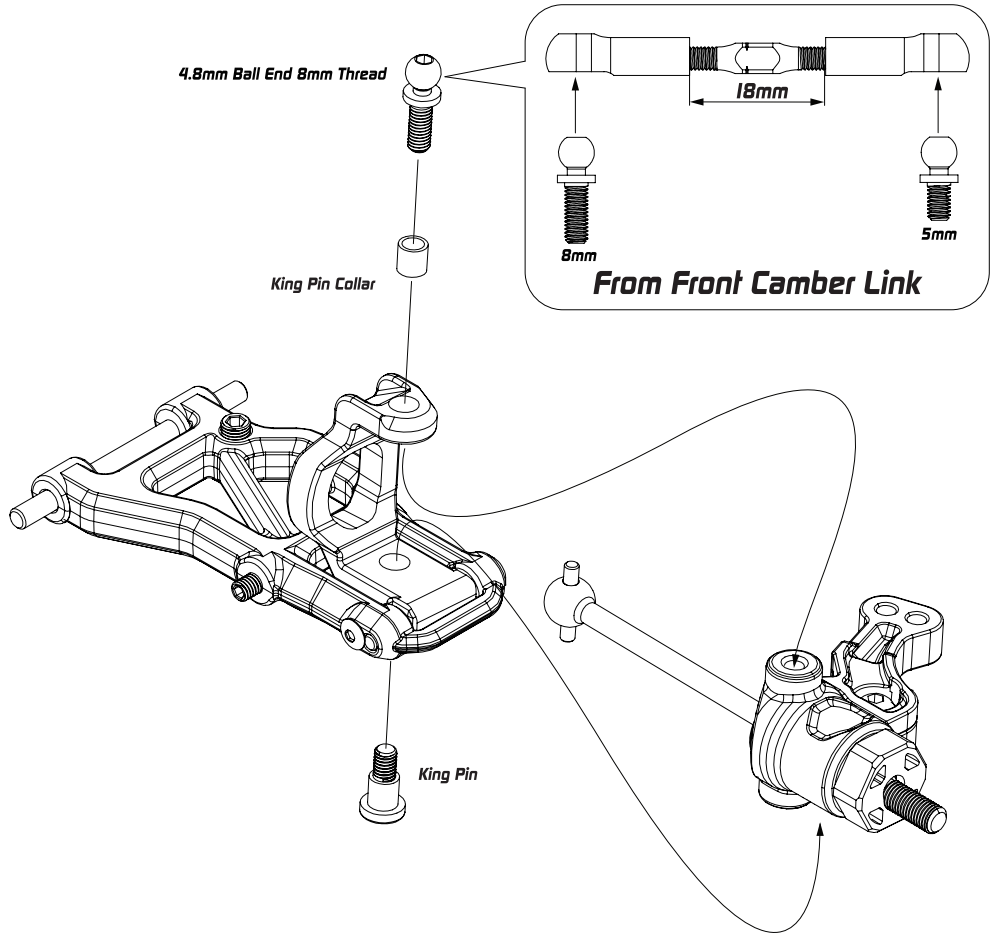

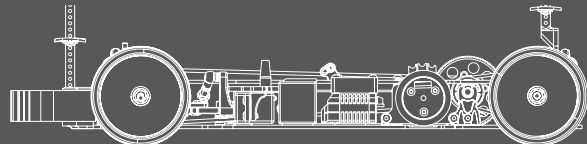

### Bag G, I, HW K



Flat Head Screw M3 x 6mm  
XP-40046



Composite Suspension Mount - FF  
XP-10260



3 x 6 x 1mm Composite Spacer  
XP-10261

Optional



**Diagonal Offset**  
Use either 0.5 or 1mm to shift the roll center in a diagonal direction from the center.



Eccentric Bushing Set  
XP-10127



**Horizontal Offset**  
Choice of either 0.5 or 1mm offset from center

Alu Front Lower 1-Piece  
Suspension Holder - FF  
XP-10114

Default Setup

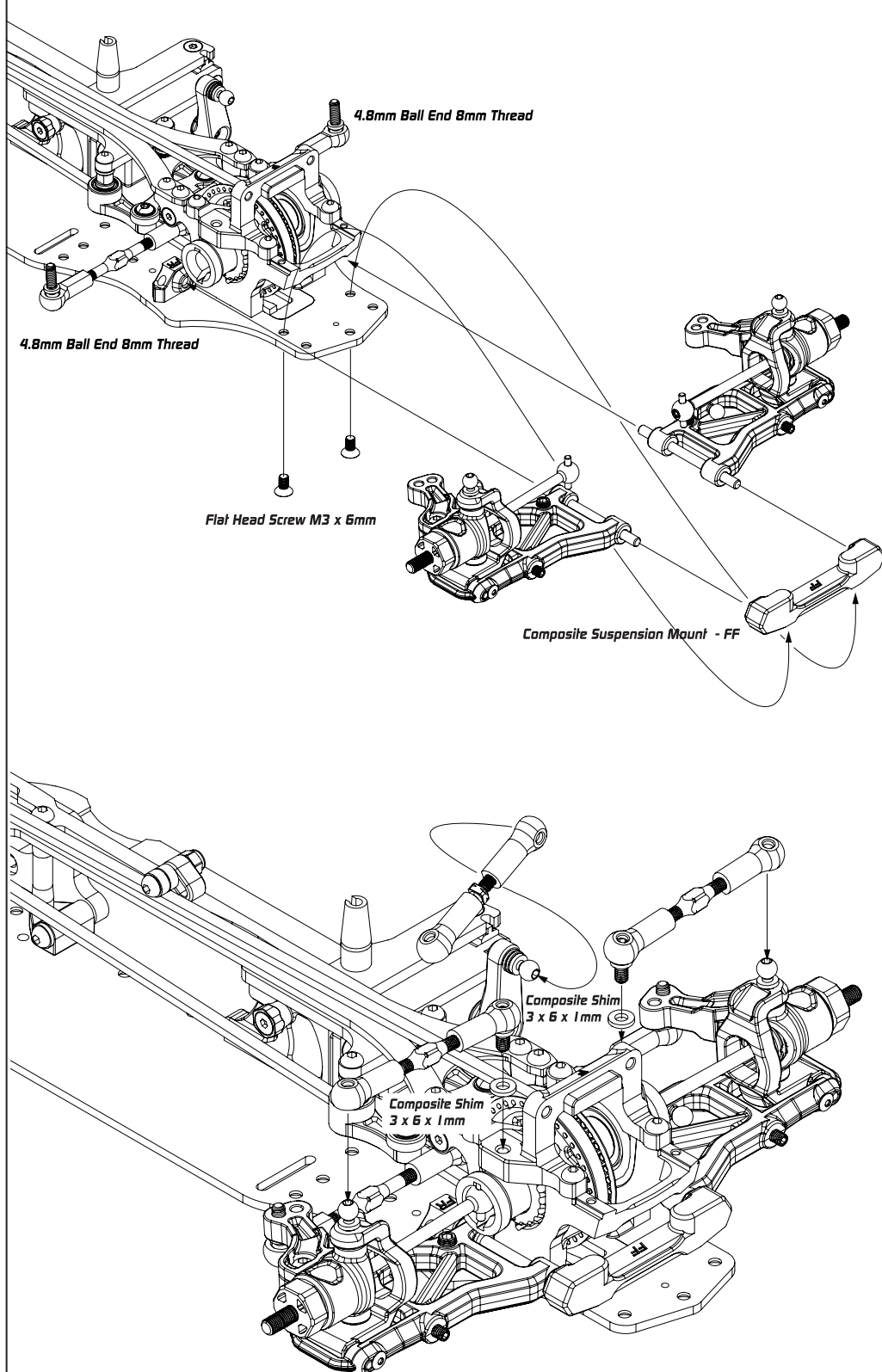

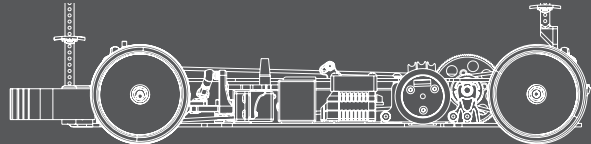

Bag K, L, HW F, H, I, K

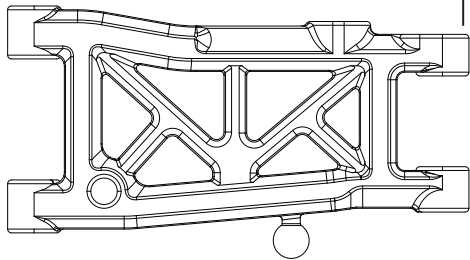

Composite Suspension Arm Rear  
XP-10108

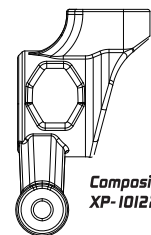

Composite Rear Upright  
XP-10122



Driveshaft Protector Blade  
XP-10128



Bearing 5 x 10 x 4mm  
XP-40064

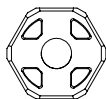

Composite Wheel Hub  
XP-10262



Pin 2 x 9.8mm  
XP-40069



Suspension Pivot Pin 3 x 42mm  
XP-10139

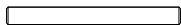

Arm Pivot Pin 2.3 x 23mm  
XP-10140



Arm Pivot Pin Screw M2 x 3.5mm  
XP-10165



Hex Set Screw M4 x 10mm  
XP-40056



Hex Set Screw M3 x 8mm  
XP-40054

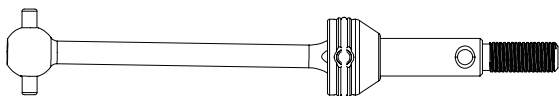

XQ1-5 Steel Universal Shaft  
XP-10244

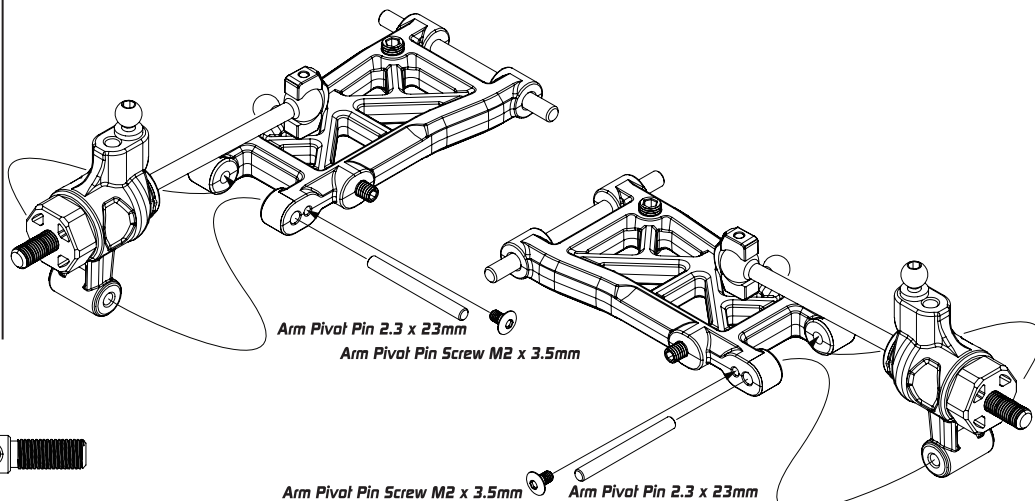
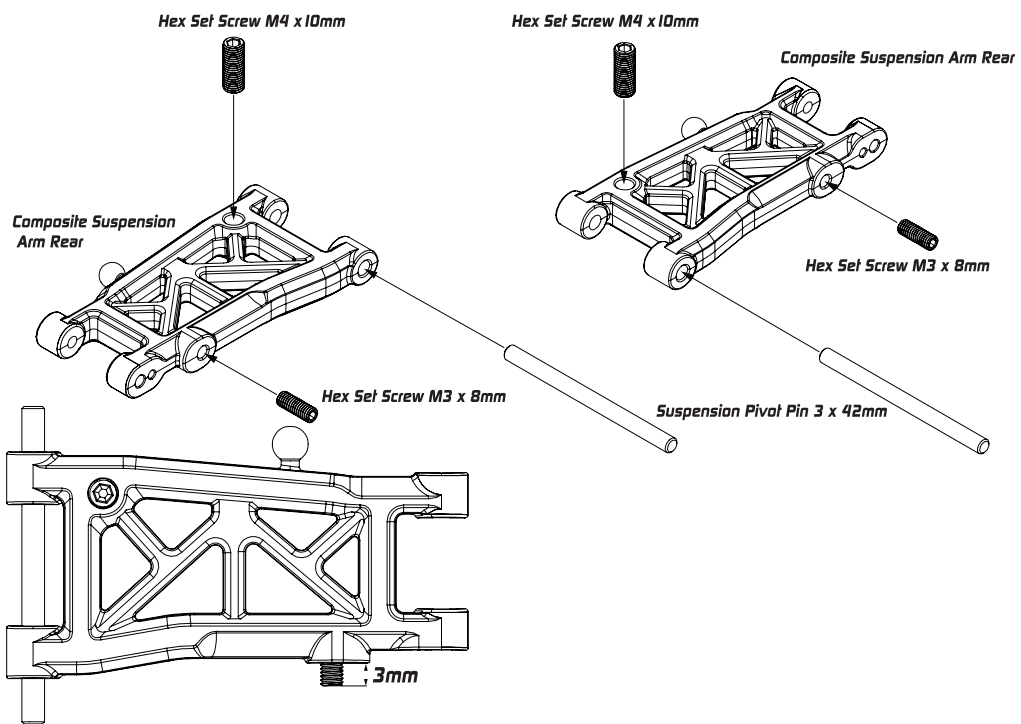
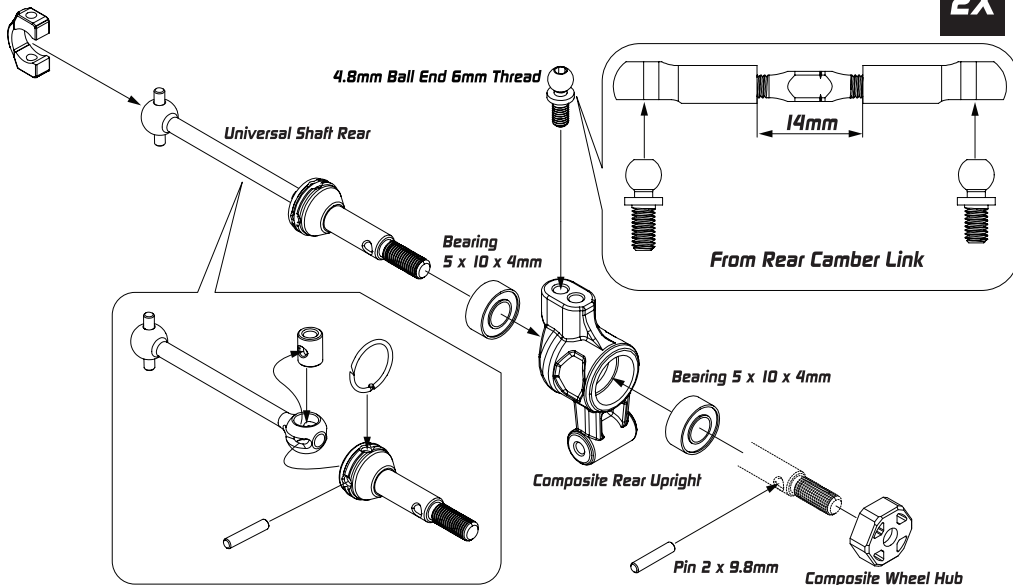



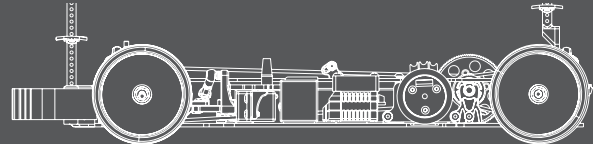

Bag G , I , HW K



Flat Head Screw M3 x 6mm  
XP-40046



Composite Suspension Mount - RR  
XP-10260



Composite Shim 3 x 6 x 1 mm

Optional

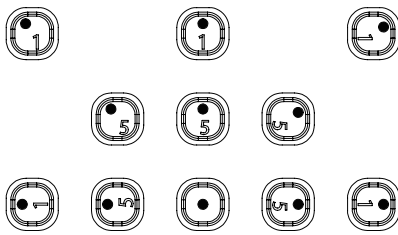

Default Setup

**Diagonal Offset**  
Use either 0.5 or 1 mm to shift the roll center in a diagonal direction from the center.

**Alu Rear Lower 1-Piece Suspension holder - RR**  
XP-10124

**Horizontal Offset**  
Choice of either 0.5 or 1 mm offset from center

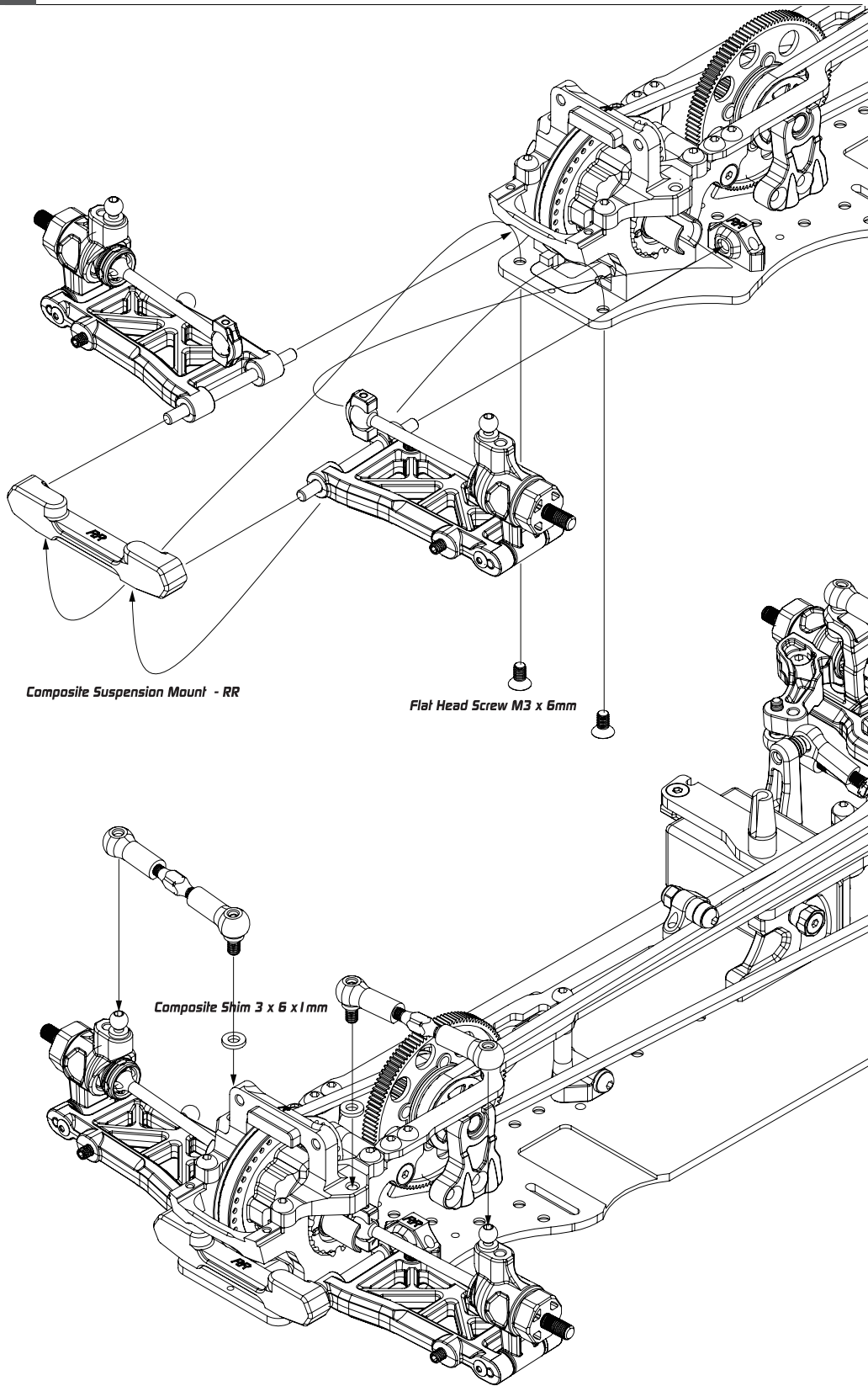
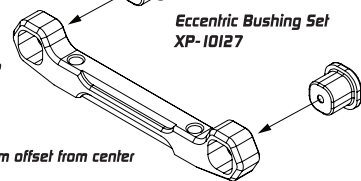

Composite Suspension Mount - RR

Flat Head Screw M3 x 6mm

Composite Shim 3 x 6 x 1 mm

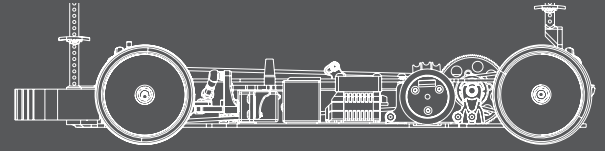

### Bag M , HW J

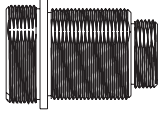

**Composite Shock Body**  
Alu Shock Body  
Option Part XP-10057

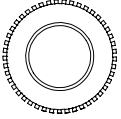

**Alu Upper Shock Cap**  
XP-10256

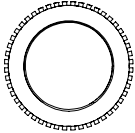

**Alu Spring Tension Adjust Nut**  
XP-10258



**Alu Lower Shock Cap**  
XP-10257



**Shock Top Connector**  
XP-10015



**2 Hole Piston**  
XP-10016



**Shock Lower Connector**  
XP-10015



**Shaft Cover**  
XP-10016



**Shaft Spacer**  
XP-10016

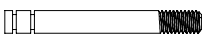

**Shock Shaft**  
XP-10050



**Shock Absorber Membrane**  
XP-10051

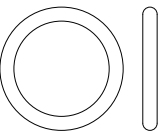

**Silicone O Ring For Spring Adjust Nut**  
XP-10051



**Shock O-Ring**  
XP-10051



**E-Clip 2.5mm**  
XP-40057

**Silicone O Ring For Spring Adjust Nut**

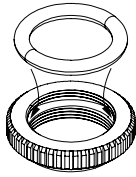

**Alu Spring Tension Adjust Nut**

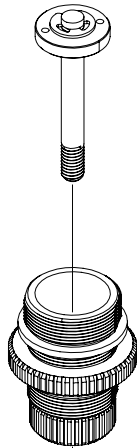
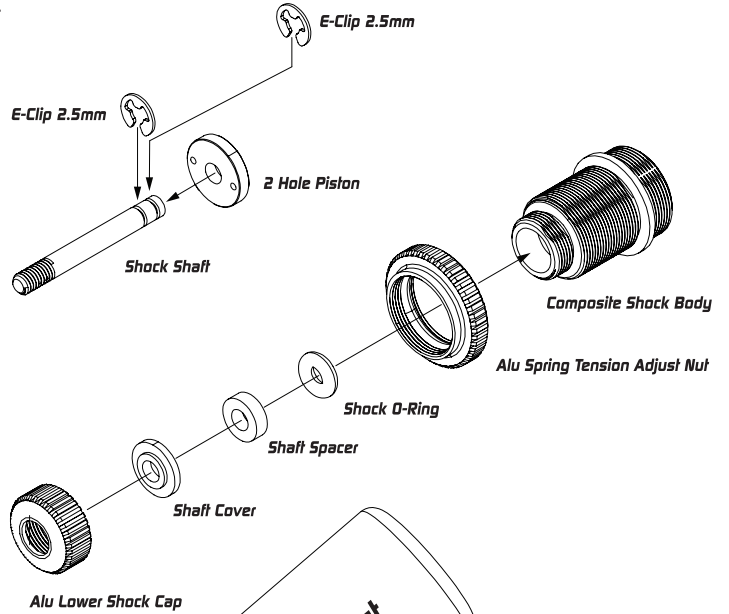

**Shock Lower Connector**

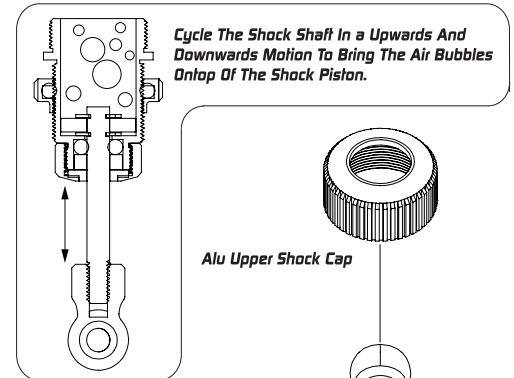

Cycle The Shock Shaft In a Upwards And Downwards Motion To Bring The Air Bubbles On/Off Of The Shock Piston.

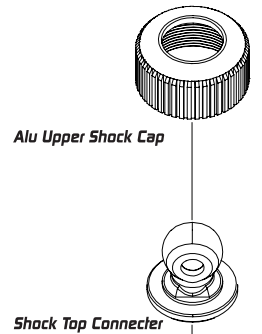

**Alu Upper Shock Cap**

**Shock Top Connector**

**Shock Absorber Membrane**

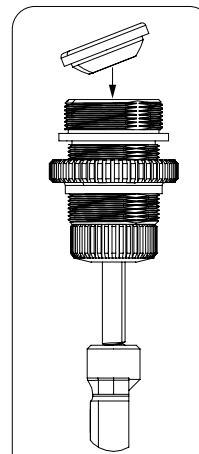

Install the shock bladder slowly on an angle as shown.

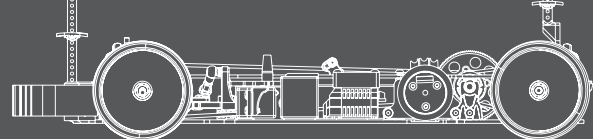

Bag M, N, FRP, HW B, I, K

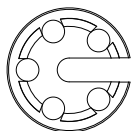

Spring Retainer  
XP-10015



Pivot Ball 4.8 mm  
XP-10045

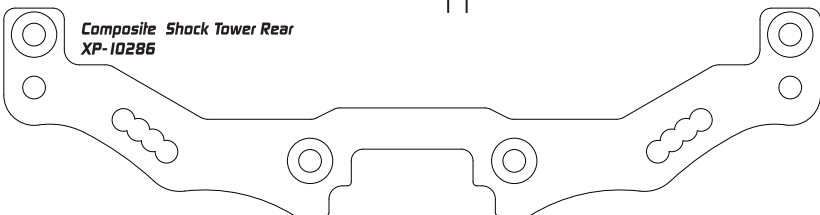

Composite Shock Tower Rear  
XP-10286

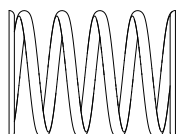

Shock Spring Medium Blue  
XP-10078

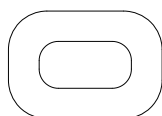

Body Height Adjuster Support  
XP-10001

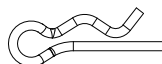

Body Clip  
XP-10055



Flat Head Screw M3 x 8mm  
XP-40048



Button Head Screw M3 x 6mm  
XP-40037

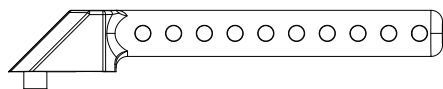

Rear Body Post  
XP-10001

Spring Retainer



4X

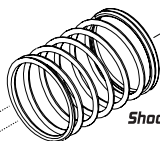

Shock Spring Blue

4X

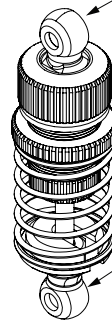

Pivot Ball 4.8 mm

Pivot Ball 4.8 mm

Body Height Adjuster Support



Body Height Adjuster Support



Body Clip



Body Clip



Flat Head Screw M3 x 8mm



FRP 3.0mm Shock Tower Rear

Flat Head Screw M3 x 8mm

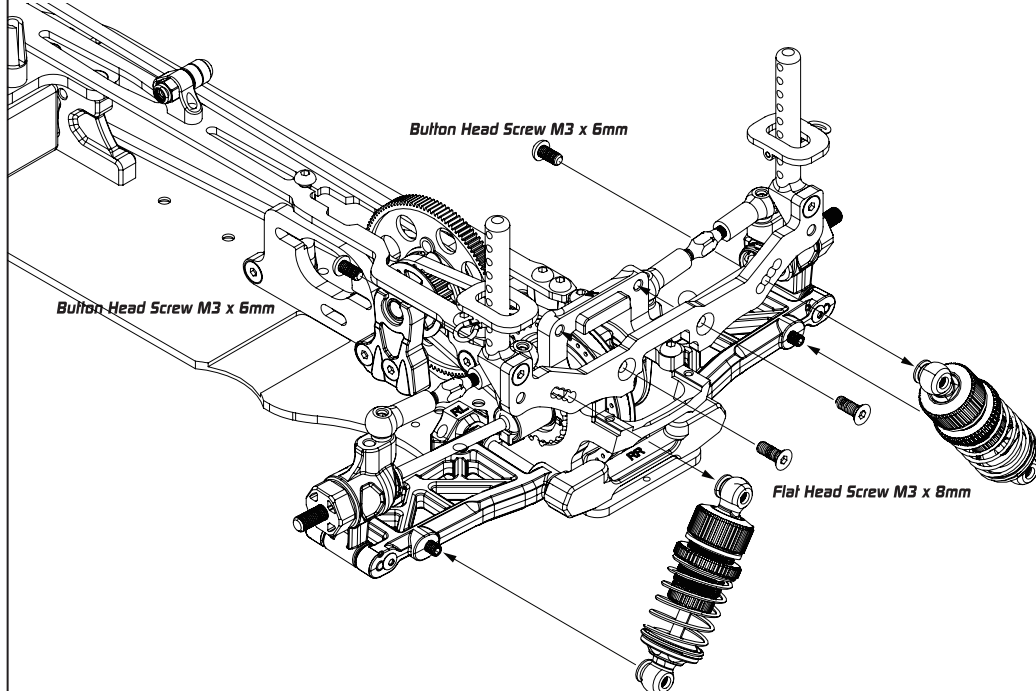

Button Head Screw M3 x 6mm



Button Head Screw M3 x 6mm

Flat Head Screw M3 x 8mm



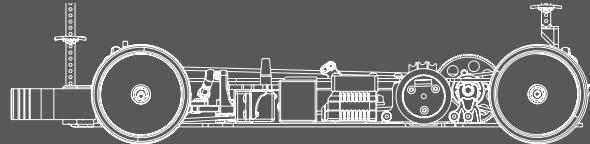

### Bag L , FRP , HW K

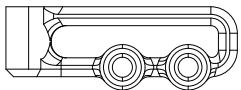

Composite Lipo Battery Backstop  
XP-10180



Flat Head Screw M3 x 8mm  
XP-40048



Flat Head Screw M3 x 6mm  
XP-40046

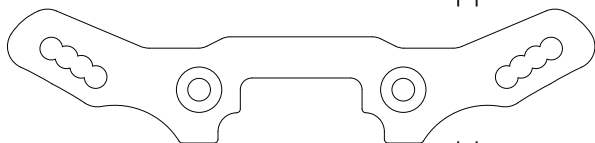

Composite Shock Tower Front  
XP-10285



Bolt Head Screw M3 x 6mm  
XP-40037

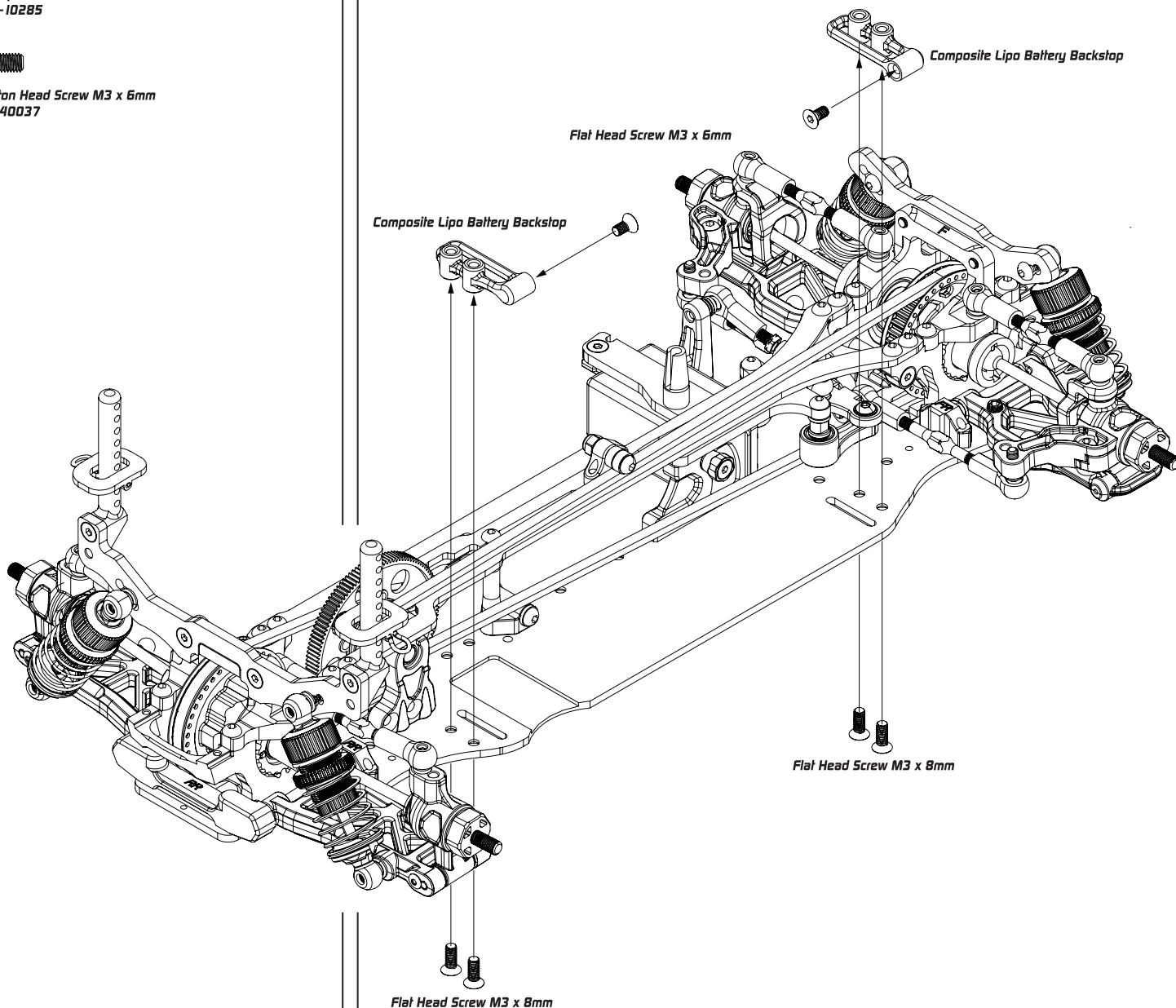
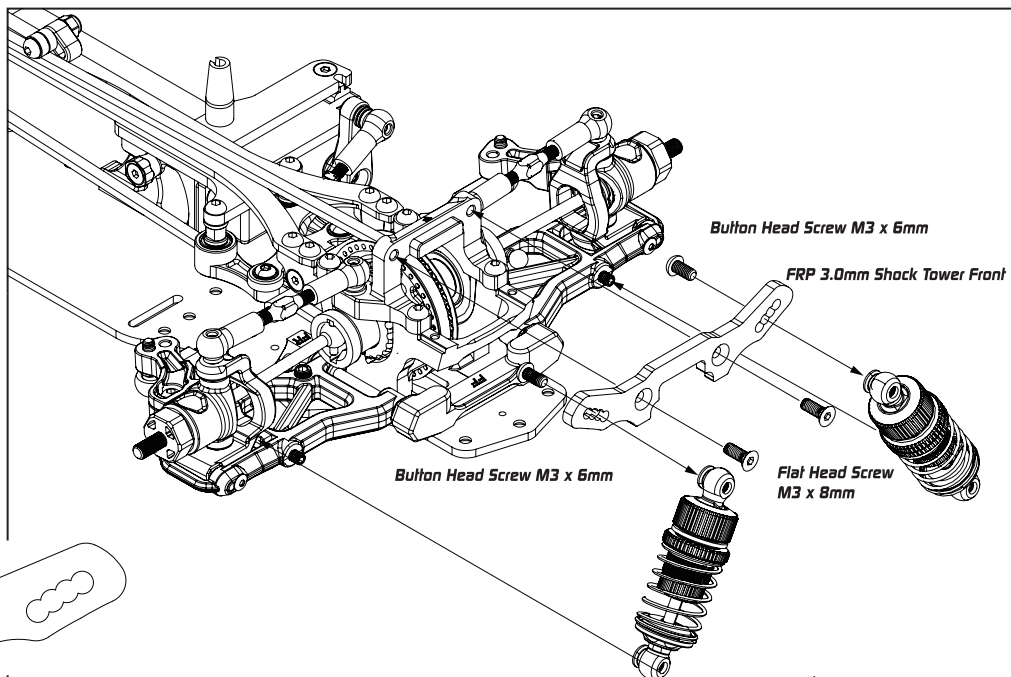

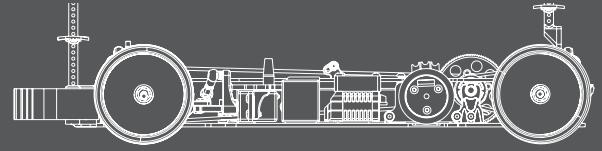

Bag N , HW I , K

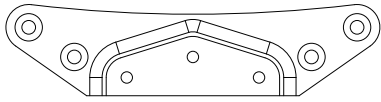

Lower Bumper  
XP-10001

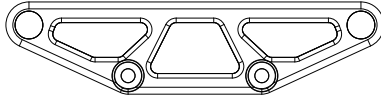

Bumper Plate  
XP-10001



Front Body Post  
XP-10001

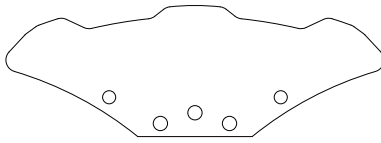

Foam Bumper  
XP-10103

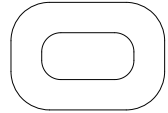

Body Height Adjuster Support  
XP-10001

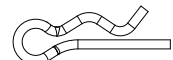

Body Clip  
XP-10055



Flat Head Screw M3 x 10mm  
XP-40049



Flat Head Screw M3 x 8mm  
XP-40048

Flat Head Screw M3 x 10mm

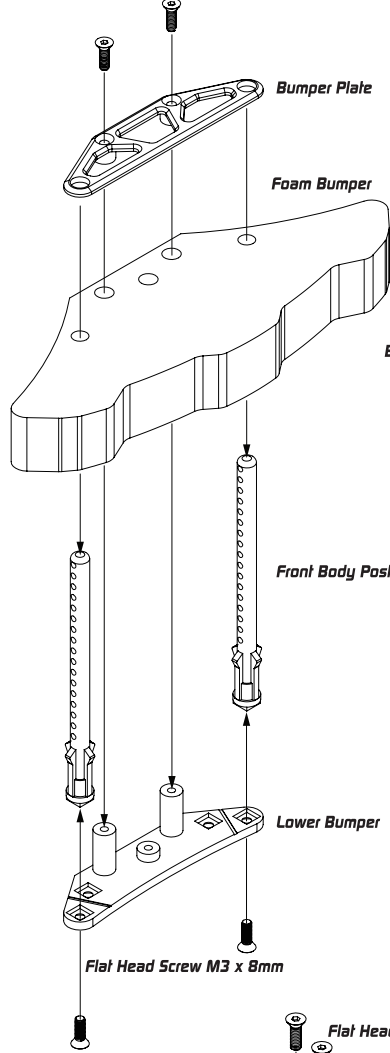

Body Height Adjuster Support

Bumper Plate

Foam Bumper

Body Clip

Body Clip

Front Body Post

Lower Bumper

Flat Head Screw M3 x 8mm

Flat Head Screw M3 x 10mm

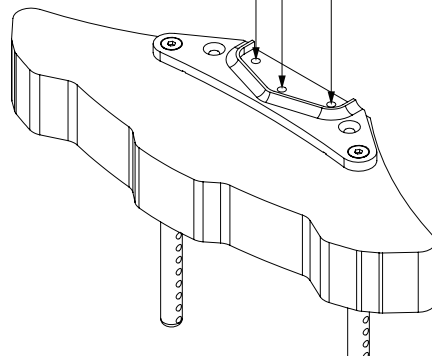

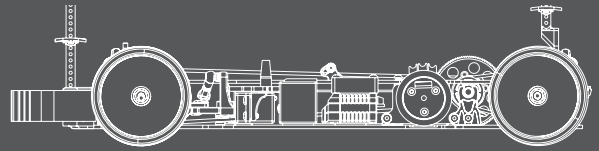

### HW K



Lock Nut 7mm  
XP-40068

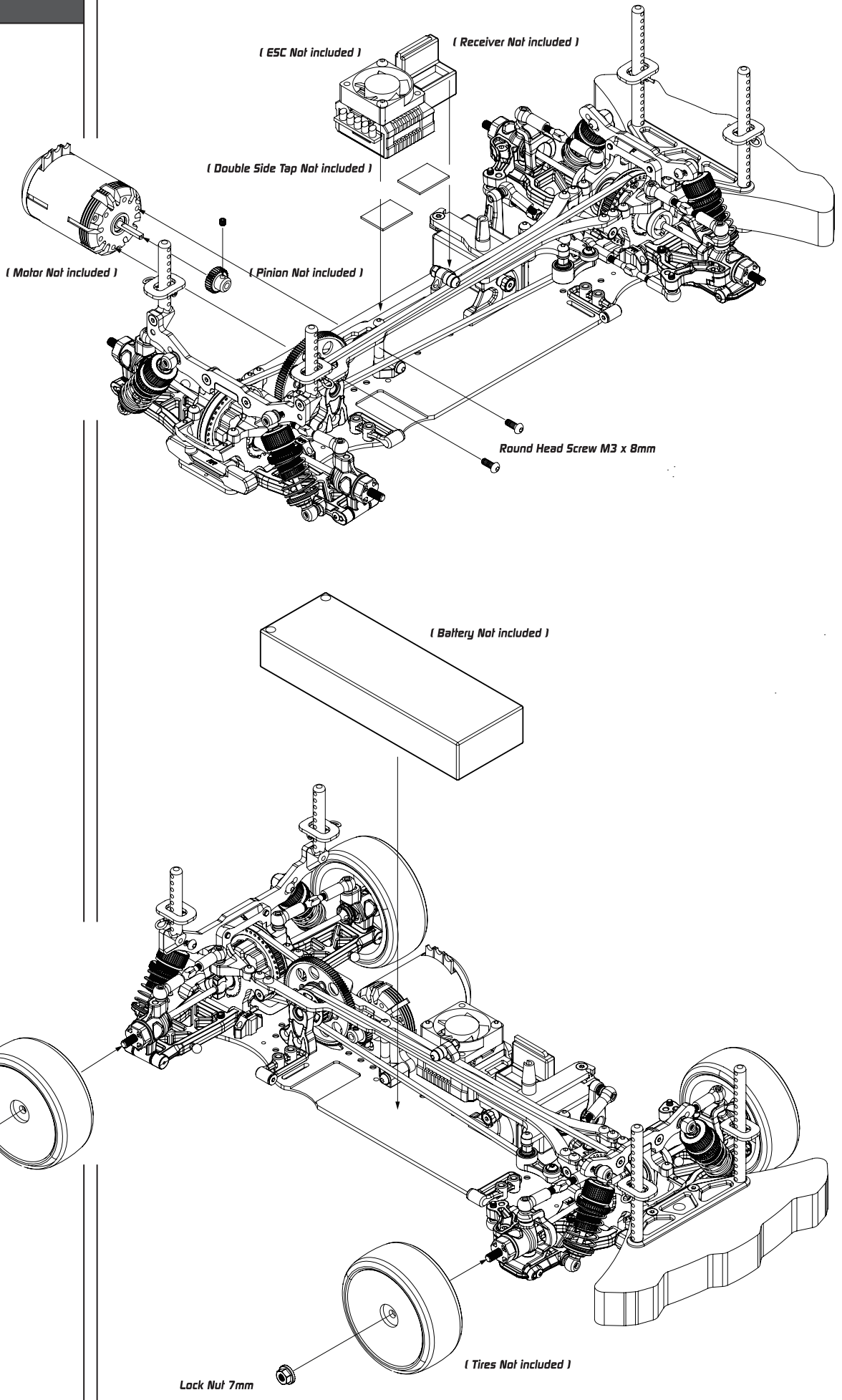

# EXECUTE XQ15 Parts List

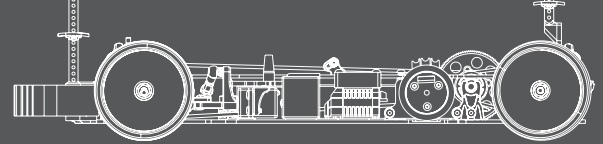

XQ15 Original Parts	
Model Number	Product Name
XP-10001	Bumper, Body Post & Antenna Holder for K1
XP-10002	4.8mm Ball End Set & Ball Bearing Hub for K1
XP-10008	Gear Differential Case and Cover
XP-10009	Gear Differential Bevel Satellite Gears Set
XP-10011	Gear Differential Re2PCS Parts
XP-10022	Gear Differential Set For Xray T4
XP-10053	Spur Gear 64P 116T
XP-10055	Body Clips (20pcs)
XP-10103	XQ1 FOAM BUMER
XP-10107	XQ1 COMPOSITE BALL BEARING TENSION ADJUSTMENT HUB 4PCS
XP-10108	XQ1 FRONT AND REAR COMPOSITE SUSPENSION ARM
XP-10109	XQ1 COMPOSITE STEERING BLOCK 2PCS
XP-10110	XQ1 COMPOSITE C HUB 4 degree DEG 2PCS
XP-10122	XQ1 COMPOSITE REAR UPRIGHT 2PCS
XP-10128	XQ1 DRIVESHAFT PROTECTOR BLADE 8PCS
XP-10134	XQ1 CENTER LAYSHAFT PULLEY
XP-10139	XQ1 3.0MM SUSPENSION PIVOT PIN 4PCS
XP-10140	XQ1 2.3MM C HUB UPRIGHT PIVOT PIN 4PCS
XP-10148	XQ1 4.8MM BALL END 5MM THREAD 10PCS
XP-10149	XQ1 4.8MM BALL END 6MM THREAD 10PCS
XP-10150	XQ1 4.8MM BALL END 8MM THREAD 10PCS
XP-10151	XQ1 4.8MM BALL END 10MM THREAD 10PCS
XP-10156	XQ1 STEEL TURNBUCKLE 29 MM 4PCS
XP-10157	XQ1 STEEL STEERING TURNBUCKLE SET
XP-10158	XQ1 Composite Suspension Parts Set
XP-10163	XQ1 COMPOSITE SERVO HORN Bell TENSIONER SET
XP-10164	XQ1 C HUB KING PIN SET (2+2)
XP-10165	XQ1 UPRIGHT PIN SCREW 2X3.5MM 10PCS
XP-10179	DIFF GASKET 10PCS
XP-10180	COMPOSITE LIPO BATTERY STOPPER 2PCS
XP-10181	Gear Differential SPACER 5X15X0.4MM 10PCS
XP-10182	Gear Differential SPACER 3.6X9.5X0.2MM 10PCS
XP-10183	SILICONE Gear Differential O-RING 25x1mm 10PCS
XP-10184	SILICONE Gear Differential O-RING 5x2mm 10PCS
XP-10185	Battery Stopper and Layshaft Bearing Holder Parts Tree
XP-10227	XQ15 Chassis Plate
XP-10228	XQ15 Top Deck
XP-10229	XQ15 Composite Lower Bulkhead
XP-10230	XQ15 Composite One Piece Upper Clamp (F/R)
XP-10231	XQ15 Composite Layshaft
XP-10232	XQ15 Alu Motor Mount Set
XP-10244	XQ15 Steel Universal Shaft 2pcs
XP-10256	XQ15 Aluminium Upper Shock Cap (2)
XP-10257	XQ15 Aluminium Lower Shock Cap (2)
XP-10258	XQ15 Aluminium Spring Tension Adjust Nut (2)
XP-10259	XQ15 Aluminium Center Post
XP-10260	XQ15 Composite Suspension Mount Set
XP-10261	XQ15 Composite Steering Set
XP-10262	XQ15 Composite Wheel Hub Set
XP-10263	XQ15 FRP Floating Servo Holder 3.0mm
XP-10264	XQ15 Composite Spool 3BT Set
XP-10265	XQ15 Composite Spool Cups
XP-10284	XQ15 Aluminium Solid Layshaft
XP-10285	XQ15 Composite Front Shock Tower
XP-10286	XQ15 Composite Rear Shock Tower
XP-10288	XQ15 Steel Gear Diff Outdrive adapter
XP-10289	XQ15 Composite Servo Mount Set
XP-10308	XQ15 Drive Belt Front 513mm
XP-10309	XQ15 Drive Belt Rear 189mm

XQ15 Option Parts	
XP-10245	XQ1 ALUMINIUM MOTOR MOUNT
XP-10246	Execute XQ1 Front And Rear Composite Suspension Arm (Hard)
XP-10247	Execute XQ1 Composite Steering Block L&R (Hard)
XP-10248	Execute XQ1 Composite C Hub 4 degree DEG L&R (Hard)
XP-10249	Execute XQ1 Composite Rear Upright 2pcs (Hard)
XP-10250	Execute XQ1 Composite Suspension Parts Set (Hard)
XP-10251	4.8mm Flat Type Ball End 15MM (4)
XP-10252	4.8mm Flat Type Ball End 13MM (2)
XP-10253	4.8mm Flat Type Ball End 10MM (4)
XP-10254	Execute XQ1 4.8mm Flat Type Ball End Set
XP-10255	Execute XQ1 Camber Stiffener Link Ball End L&R
XP-10282	XQ15 Anti-Roll Bar set
XP-10283	XQ15 Anti-Roll Bar Bushing(4+2)
XP-10287	XQ1 Anti-Tweak Battery Holder

XQ15 Option Parts	
Model Number	Product Name
XP-10052	KEVLAR DRIVE BELT REAR 3 x 189 MM
XP-10101	XQ1 GRAPHITE 2.25MM BOTTOM CHASSIS PLATE
XP-10102	XQ1 GRAPHITE 2.0MM UPPER DECK
XP-10104	XQ1 ALUMINIUM FRONT 1 PIECE UPPER CLAMP
XP-10105	XQ1 FRONT CAMBERLINK MOUNT 2PCS
XP-10106	XQ1 GRAPHITE 3.0MM FRONT SHOCK TOWER
XP-10111	XQ1 ALUMINIUM DUAL SERVO SAVER ARM 2PCS
XP-10112	XQ1 ALUMINIUM STEERING POST FOR DUAL SERVO SAVER 2PCS
XP-10113	XQ1 ALUMINIUM STEERING PLATE FOR DUAL SERVO SAVER 4mm
XP-10114	XQ1 ALUMINIUM FF LOWER 1 PIECE SUSPENSION MOUNT
XP-10115	XQ1 ALUMINIUM LOWER BULKHEAD
XP-10116	XQ1 ALUMINIUM LAYSHAFT HOLDER BULKHEAD 2PCS
XP-10118	XQ1 GRAPHITE 3.0MM REAR SHOCK TOWER
XP-10119	XQ1 ALUMINIUM SHIM 3x6x1.0MM RED (20)
XP-10120	XQ1 ALUMINIUM SHIM 3x6x2.0MM RED (20)
XP-10121	XQ1 5.8 MM PIVOT BALL 8PCS
XP-10123	XQ1 ALUMINIUM 2 PIECE SUSPENSION MOUNT 2PCS
XP-10124	XQ1 ALUMINIUM RR LOWER 1 PIECE SUSPENSION MOUNT
XP-10125	XQ1 ALUMINIUM GEAR DIFF OUTDRIVE ADAPTER 2PCS
XP-10126	XQ1 STEEL SPOOL OUTDRIVE ADAPTER 2PCS
XP-10127	XQ1 ECCENTRIC BUSHING SET 4PCS
XP-10129	XQ1 ALUMINIUM 5MM WHEEL HUB RED 2PCS
XP-10130	XQ1 REAR 1 PIECE UPPER CLAMP
XP-10131	XQ1 REAR CAMBERLINK MOUNT 2PCS
XP-10132	XQ1 KEVLAR FRONT DRIVE BELT 3 x 513 MM
XP-10133	XQ1 ALUMINIUM SOLID AXLE
XP-10135	XQ1 Motor Mount Post
XP-10136	XQ1 ALUMINIUM SERVO MOUNT
XP-10137	XQ1 3.0MM GRAPHITE FLOATING SERVO HOLDER
XP-10138	XQ1 3.0MM GRAPHITE CHASSIS STIFFENER
XP-10141	XQ1 ALUMINIUM SHOCK SET 2PCS
XP-10142	XQ1 ALUMINIUM SHOCK BODY 2PCS
XP-10143	XQ1 SHOCK SHAFT 2PCS
XP-10144	XQ1 COMPOSITE SHOCK PARTS TREE
XP-10145	XQ1 ALUMINIUM LOWER SHOCK CAP 2PCS
XP-10146	XQ1 ALUMINIUM UPPER SHOCK CAP 2PCS
XP-10147	XQ1 SHOCK MEMBRANE 8PCS
XP-10152	XQ1 ALUMINIUM ANTI-ROLL BAR BUSHING (4+4)
XP-10153	XQ1 ALUMINIUM 2.0MM BOTTOM CHASSIS PLATE
XP-10154	XQ1 GRAPHITE 1.6MM UPPER DECK
XP-10155	XQ1 BALL BEARING ANTI-ROLL BAR SET 6PCS
XP-10159	XQ1 COMPOSITE 1.1MM PISTON SPACER SET
XP-10160	XQ1 SHOCK O-RING 8PCS
XP-10161	XQ1 ALUMINIUM SPRING TENSION ADJUST NUT 2PCS
XP-10162	XQ1 SILICONE O RING FOR SPRING ADJUST NUT 4PCS
XP-10166	XQ1 STEEL DOUBLE JOINT UNIVERSAL SHAFT 2PCS
XP-10167	XQ1 STEEL UNIVERSAL SHAFT REAR 2PCS
XP-10168	XQ1 Spring 2PCS Soft BK
XP-10169	XQ1 Spring 2PCS Medium SV
XP-10170	XQ1 Spring 2PCS Stiff PK
XP-10171	XQ1 PROGRESSIVE SHOCK SPRING SOFT 2PCS
XP-10172	XQ1 PROGRESSIVE SHOCK SPRING MEDIUM 2PCS
XP-10173	XQ1 PROGRESSIVE SHOCK SPRING STIFF 2PCS
XP-10174	XQ1 PROGRESSIVE SHOCK SPRING SET (6)
XP-10175	XQ1 ALUMINIUM SOLID LAYSHAFT
XP-10176	XQ1 ANTI-ROLL BAR 1.2MM (F/R)
XP-10177	XQ1 ANTI-ROLL BAR 1.3MM (F/R)
XP-10178	XQ1 ANTI-ROLL BAR 1.4MM (F/R)
XP-10186	XQ1 Brass Chassis Balancing Weights 8PCS
XP-10187	XQ1 Central Brass Chassis Balancing Weights 25g
XP-10188	CAMBERLINK SHIM 0.5 IMM
XP-10189	MOTORMOUNT FLEX ADJUSTMENT PLATE
XP-10190	ALUMINIUMMINUM BLADE SPOOL CUP
XP-10191	RF ONE PIECE SUSPENSION MOUNT
XP-10192	ALUMINIUMMINUM ADJUSTABLE BATTERY STOPPERS
XP-10193	ALUMINIUMMINUM SPRING RETAINER
XP-10194	FR ONE PIECE SUSPENSION MOUNT
XP-10220	Execute XQ1 Camberlink Stiffener set
XP-10221	Option Servo Mount Plate (Wire Hide)
XP-10222	Graphite Option Steering Knuckle plate
XP-10223	XQ1 Aluminium Steering Plate For Dual Servo Saver 3.5mm
XP-10224	XQ1 Aluminium Steering Plate For Dual Servo Saver 5mm
XP-10225	XQ1 Aluminium Ball Bearing Tension Adjustment Hub 2pcs
XP-10226	XQ1 Steering Toe-In Adjustment Post



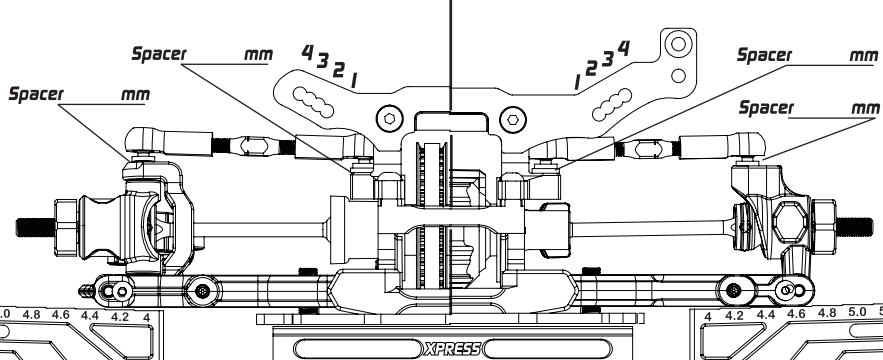
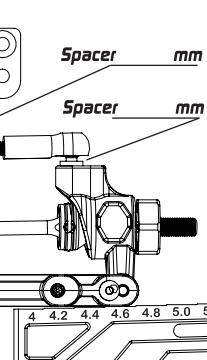
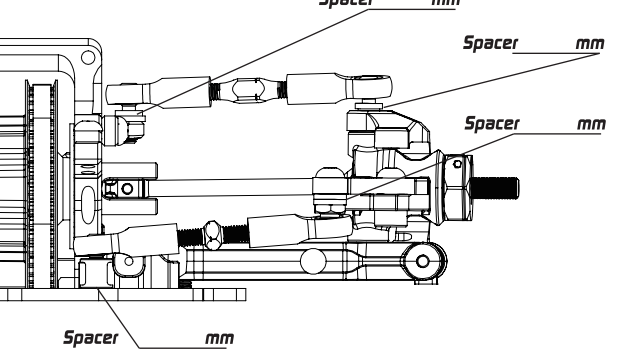

**Driver** \_\_\_\_\_ **Track Surface** \_\_\_\_\_ **Track Temperature** \_\_\_\_\_  
**Date** \_\_\_\_\_ **Track Traction** \_\_\_\_\_ **Result** \_\_\_\_\_ **Air Temperature** \_\_\_\_\_  
**Track** \_\_\_\_\_ **Country** \_\_\_\_\_ **Best Lap** \_\_\_\_\_ **Humidity** \_\_\_\_\_ **Remark** \_\_\_\_\_

Front	Rear	Optional	On-Power Control System
 <p> <input type="checkbox"/> M <input type="checkbox"/> H  <b>Steering Block</b>  <input type="checkbox"/> M <input type="checkbox"/> H  <b>Suspension Arm</b>  <input type="checkbox"/> M <input type="checkbox"/> H         </p>	 <p> <input type="checkbox"/> M <input type="checkbox"/> H  <b>Suspension Arm</b>  <input type="checkbox"/> M <input type="checkbox"/> H         </p>	 <p> <input type="checkbox"/> M <input type="checkbox"/> H  <b>Suspension Arm</b>  <input type="checkbox"/> M <input type="checkbox"/> H         </p>	<p> <b>Steering Block</b>  <input type="checkbox"/> M <input type="checkbox"/> H  <b>Suspension Arm</b>  <input type="checkbox"/> M <input type="checkbox"/> H         </p>
<p> <b>C-Hub</b> _____ <b>Hex Offset</b> _____ mm _____ mm  <b>Steering Block</b> _____ <b>Camber</b> _____  <input type="checkbox"/> M <input type="checkbox"/> H <b>Ride Height</b> _____ mm _____ mm  <b>Suspension Arm</b> _____ <b>DownStop</b> _____ mm _____ mm  <input type="checkbox"/> M <input type="checkbox"/> H <b>Sway Bar</b> _____ mm _____ mm         </p>	<p> <b>Rear Hub</b> _____ <b>Hex Offset</b> _____ mm  <input type="checkbox"/> M <input type="checkbox"/> H <b>Camber</b> _____  <b>Suspension Arm</b> _____ <b>Ride Height</b> _____ mm  <input type="checkbox"/> M <input type="checkbox"/> H <b>DownStop</b> _____ mm  <b>Sway Bar</b> _____ mm         </p>		

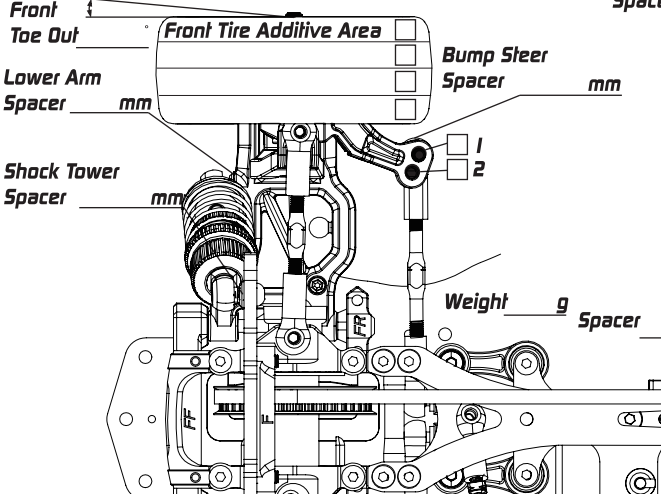
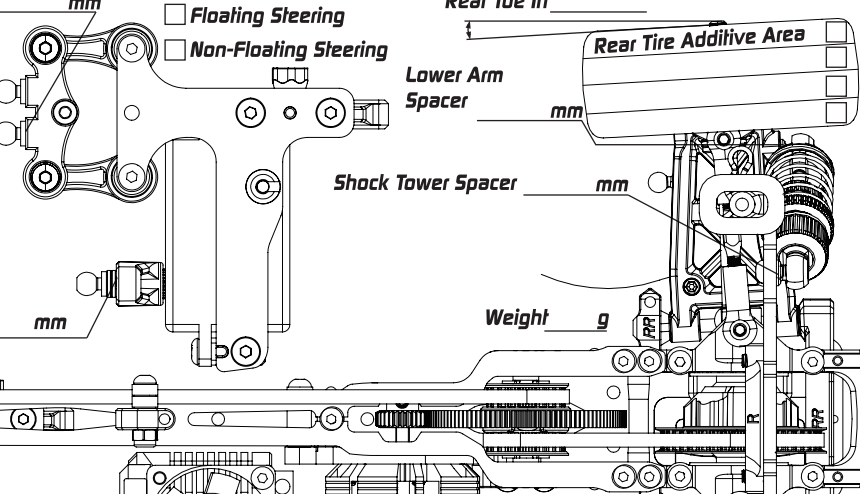
 <p> <b>Front Toe Out</b> _____  <b>Lower Arm Spacer</b> _____ mm  <b>Shock Tower Spacer</b> _____ mm  <b>Weight</b> _____ g  <b>Front Tire Additive Area</b> _____  <b>Bump Steer Spacer</b> _____ mm         </p>	 <p> <b>Rear Toe In</b> _____  <b>Lower Arm Spacer</b> _____ mm  <b>Shock Tower Spacer</b> _____ mm  <b>Weight</b> _____ g  <b>Rear Tire Additive Area</b> _____         </p>
<p> <input type="checkbox"/> Floating Steering  <input type="checkbox"/> Non-Floating Steering         </p>	

### Suspension Mount Setup

<b>FF</b> <input type="checkbox"/> 1 <input type="checkbox"/> 0.5	<b>FR</b> <input type="checkbox"/> 1 <input type="checkbox"/> 0.5
<b>RR</b> <input type="checkbox"/> 1 <input type="checkbox"/> 0.5	<b>RF</b> <input type="checkbox"/> 1 <input type="checkbox"/> 0.5

### Optional Center Line Flex Control

<input type="checkbox"/> Turnbuckle <input type="checkbox"/> Carbon Fiber <input type="checkbox"/> None	<input type="checkbox"/> Center Post <input type="checkbox"/> Nut
<b>Spacer</b> _____ mm <b>Lower Screw</b> _____	

### Damper Setup

Front	Rear
<b>Spring</b> _____ <b>Oil</b> _____ <b>Rebound</b> _____ <b>Piston</b> _____ <b>Length</b> _____ <b>Foam Insert</b> <input type="checkbox"/> <b>Hole In Cap</b> <input type="checkbox"/>	<b>Foam Insert</b> <input type="checkbox"/> <b>Hole In Cap</b> <input type="checkbox"/>

### Transmission Setup

Front	Rear
<b>Oil</b> _____ <b>Weight</b> _____ g <b>Position</b> _____	<b>Gear Diff</b> _____ <b>Oil</b> _____ <b>Weight</b> _____ g <b>Position</b> _____

### Others

**Servo** \_\_\_\_\_ **Tires** \_\_\_\_\_  
**Esc** \_\_\_\_\_ **Additive** \_\_\_\_\_  
**Motor** \_\_\_\_\_ **Body** \_\_\_\_\_  
**Spur** \_\_\_\_\_ P/ \_\_\_\_\_ T Rear Wing \_\_\_\_\_  
**Pinon** \_\_\_\_\_ P/ \_\_\_\_\_ T FDR \_\_\_\_\_

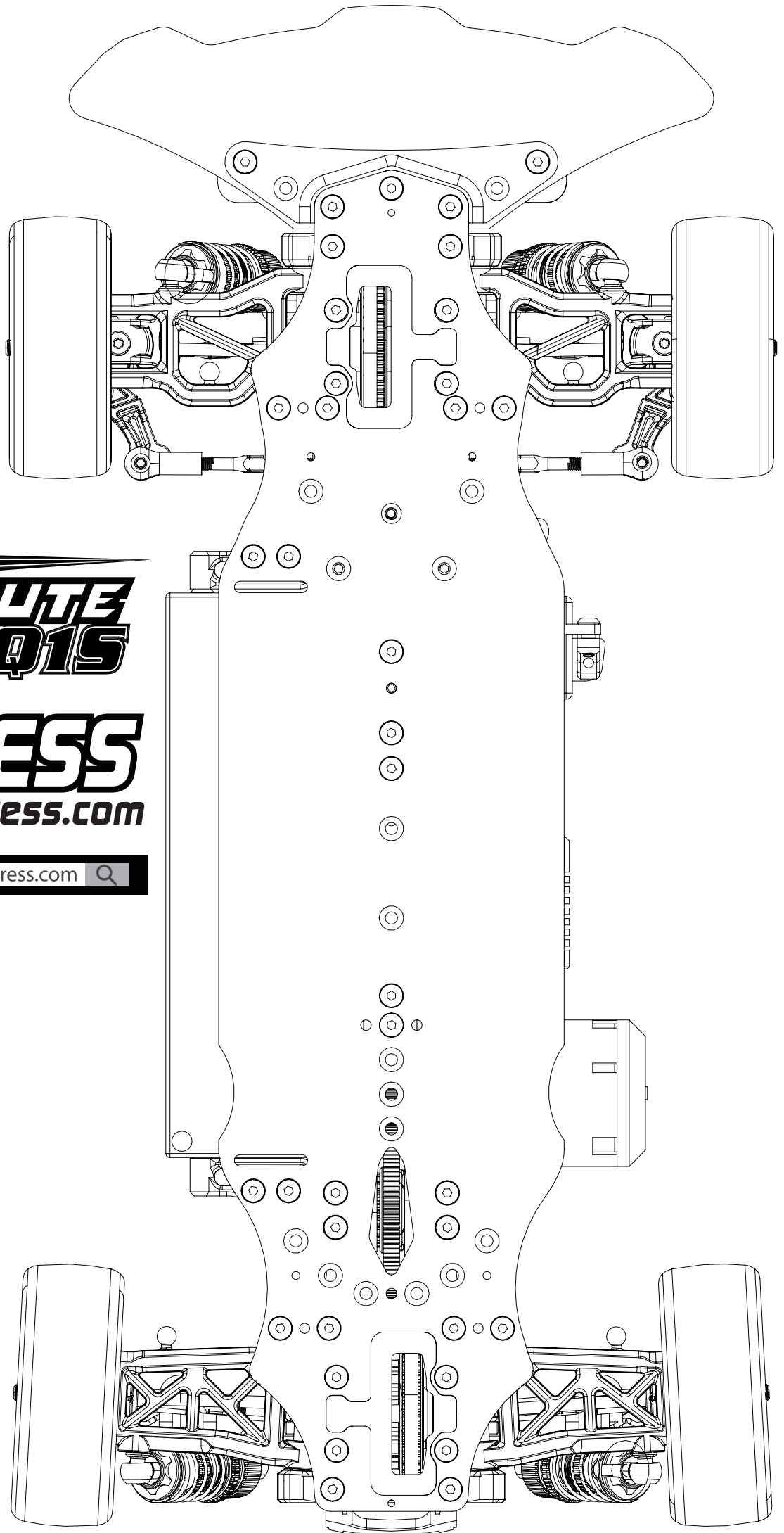

**EXECUTE**  
**XQ15**  
1/10 COMPETITION TOURING CAR

**XPRESS**  
[www.rc-xpress.com](http://www.rc-xpress.com)

